

# Watt-hour Meter Interface Module

## MIM-B16\* PIM (Pulse Input Module)

Watt-hour Meter Interface Module can be exclusively used for DMS 2 power distribution, displaying power consumption for each watt-hour meter.

- Exclusive use for DMS 2 power distribution
- Connection with up to 8 watt-hour meters
- Pulse interface with watt-hour meters
- Power consumption display for each watt-hour meter



## Connectable Watt-hour meter with PIM

- Wh/Pulse Range : 1~10000 Wh/Pulse (no decimal place)
- Pulse Width Range : 20~400ms
- Interval between Pulses : Minimum of 3ms

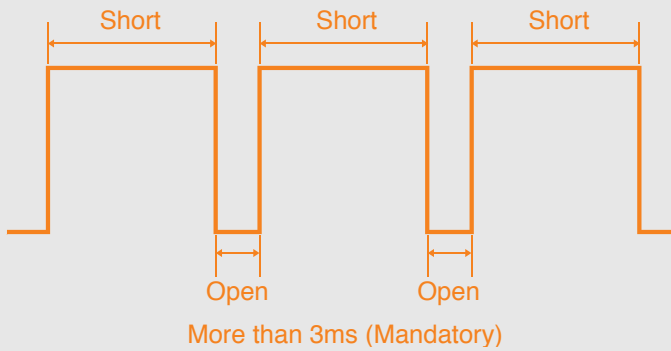

## Connection

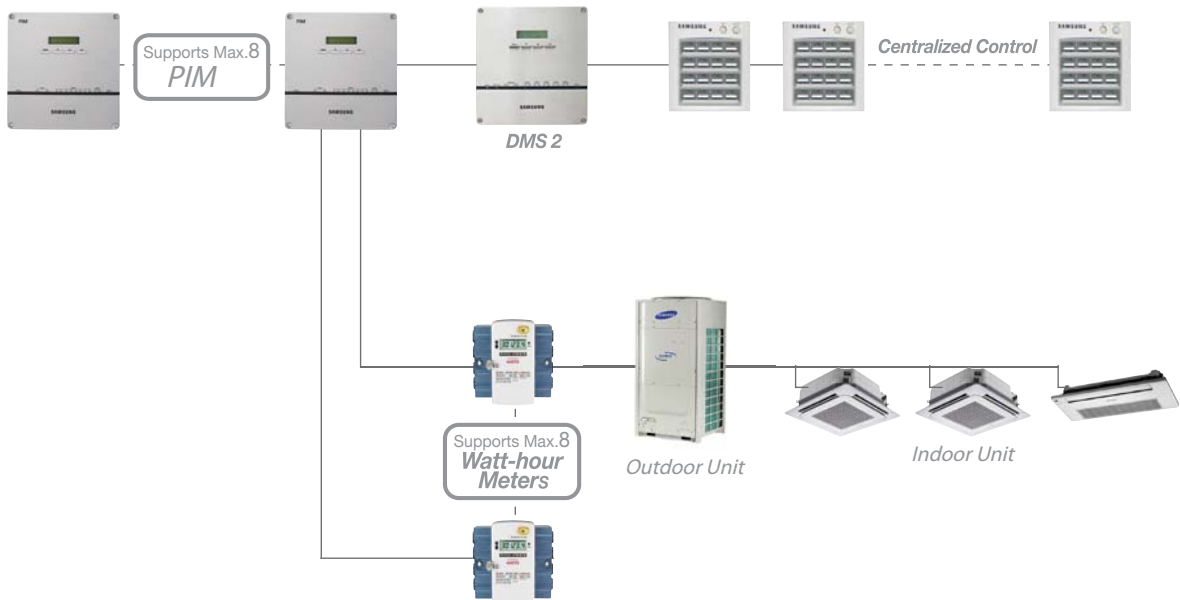

# IV Power distribution system

## 1. Electricity meter interface module

□ MIM-B16

### 1) Features

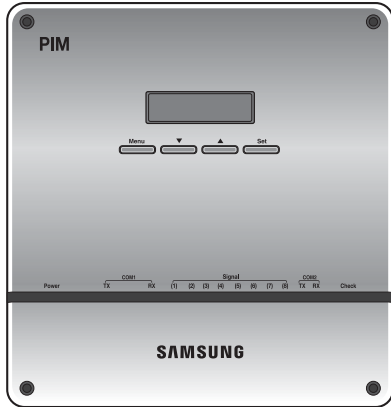

- Pulse output electricity meter interface unit (max. 8 meters)
- 8-channel energy consumption display in real time
- System configuration with button manipulation
- Various text messages in LCD
- Current communication state indication

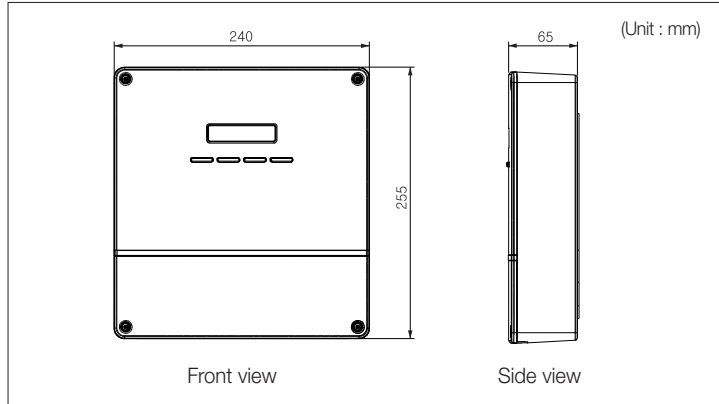

Power supply (adapter)	Input : 100~240V AC, 50/60Hz, 1.0A Output : 12V DC, 3.0A
Operating temperature range	-10°C ~ 50°C
Operating humidity range	10%RH~90%RH
Maximum wiring length	DMS2 : 1000m Electricity meter : 200m
Number of interfaces	Electricity meter : max. 8 units DMS2 : 1 unit

### 2) Display and buttons

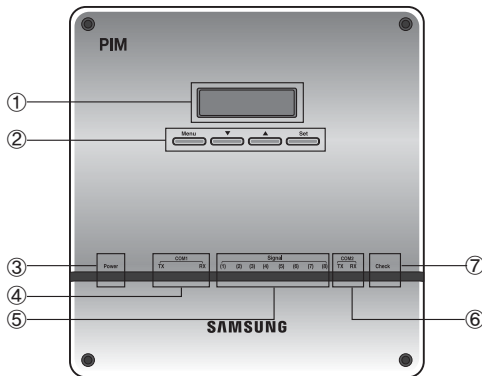

No.	Name	Description
①	LCD window	Information on current electricity readings, settings and operation state is displayed (16 character x 2 line LCD).
②	Menu button	Various menus are selected to monitor current electricity readings, to make configuration settings for electricity meters, and to check the error/settings.
③	Power (blue)	It's ON when power is supplied normally.
④	Communication (orange)	It blinks when communication between DMS2 and MIM-B16 normally works.
⑤	Pulse input (orange)	Each of the 8 LEDs blinks whenever a pulse from an electricity meter is detected.
⑥	Communication (orange)	Reserved
⑦	Check	It's ON when errors occur in communication or pulse input from electricity meters.

### 3) Connectors

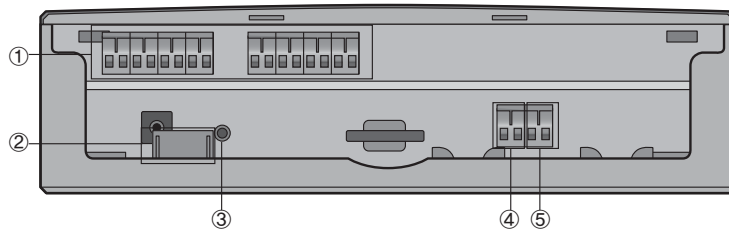

No.	Name	Description
①	Pulse input terminals	8 terminals are allocated to interface pulse-type electricity meters. Each terminal is seen with a dedicated address on DMS2.
②	Power input	Power supply via the power adapter.
③	Reset button	Press the button to reset the MIM-B16.
④	COM1	Connection terminal for RS485 communication with DMS2.
⑤	COM2	Reserved

### 4) Address & option switches

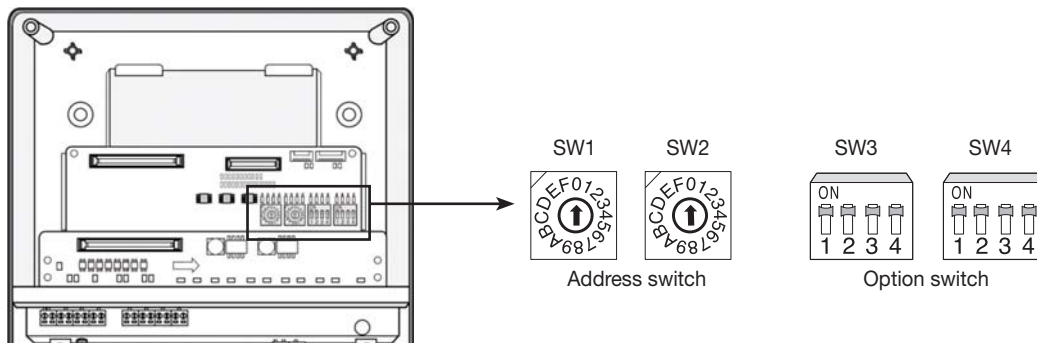

No	Name	Description
1	SW1	No function
2	SW2	MIM-B16 address switch. Address greater than 7 (8~F) is not recognized.
3	SW3	No function
4	SW4	No function

# IV Power distribution system

## 1. Electricity meter interface module

### □ MIM-B16

#### 5) Specifications on electricity meter

- Current flow on output : Current-sinking
- Pulse rate : 1 ~ 10000 Wh/pulse (no decimal pulse rate allowed)
- Pulse width : 20 ~ 400ms with +/- 5% tolerance (no decimal pulse rate allowed)
- Time interval between pulses : min. 3ms
- Allowable current sinking : min. 15mA
- Withstanding voltage : min. 15V DC
- Interface circuitry : Electronic isolation circuitry recommended, no voltage output

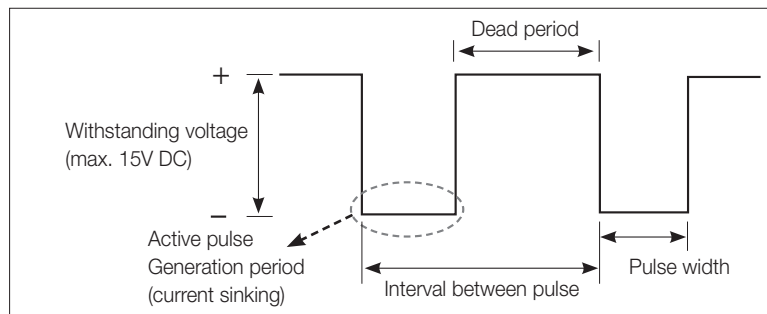
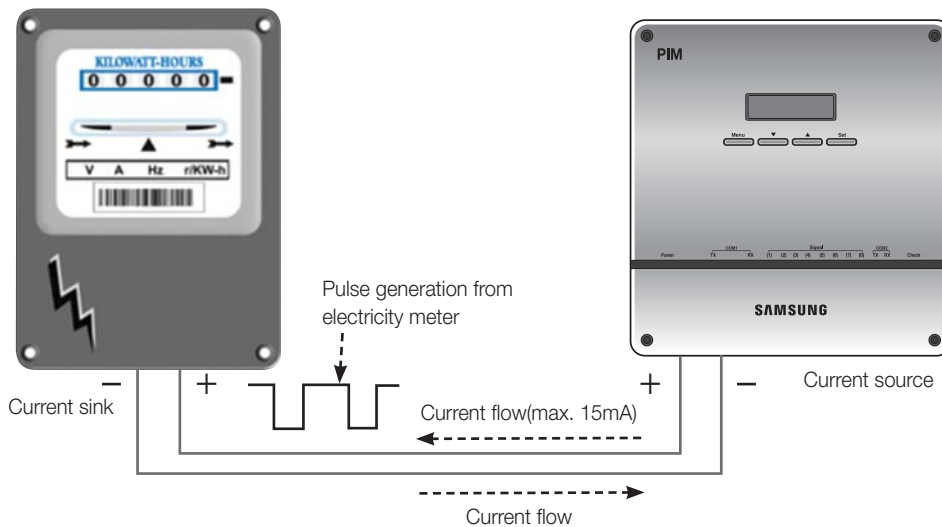

#### ☑ Note

- ♦ Interface circuitry of an electricity meter has to withstand min. 15mA and min. 15V DC, both of which are applied by MIM-B16.
- ♦ Even though MIM-B16 interface circuitry is realized with electric isolation components, it's highly recommended that interface circuitry of an electricity meter be designed with isolation to ensure robustness from contact spike or electric interference during wiring.

## 6) Installation

MIM-B16 must not be installed in a way that power to MIM-B16 is off when one of the over-current circuit breakers is switched off. Power supply to MIM-B16 must be off only when all the power supplies to refrigerant systems whose power consumptions are monitored by the MIM-B16 are cut off. This is because every pulse from electricity meters of some alive refrigerant systems must be sensed normally even if power supplies to other refrigerant systems have troubles.

- Example 1) When the circuit breaker, CM1 is switched off for some reason while the others are still on, pulses from the electricity meters, EM1, EM2 and EM3 are not calculated by MIM-B16, whose power is off by the CM1. This installation could lead to errors in electricity billing function when power interruption in local areas occurs.

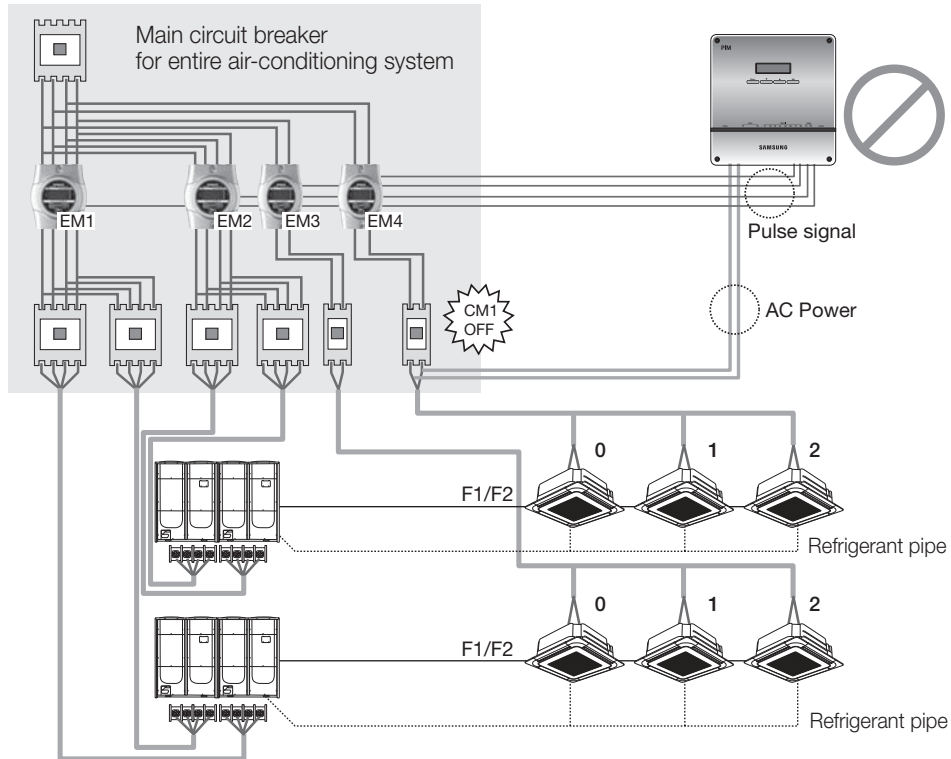

- Example 2) Even when the circuit breaker, CM1 is switched off while the others are on, pulses from the electricity meters, EM1, EM2 and EM3 are still calculated by MIM-B16, whose power is not interrupted by CM1.

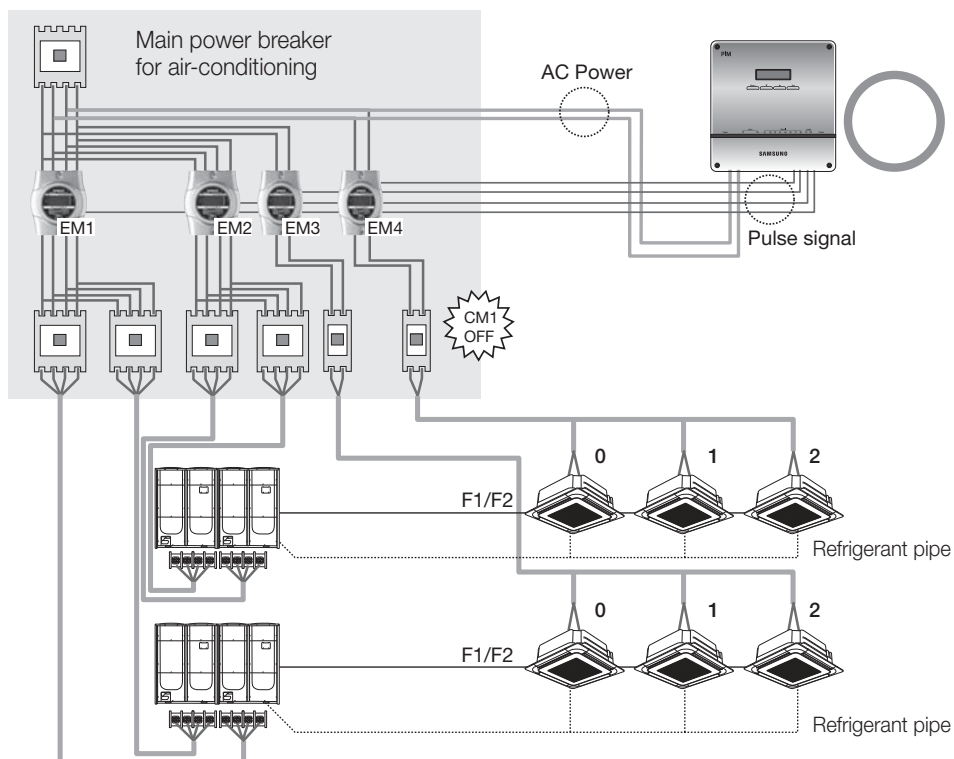

# IV Power distribution system

## 1. Electricity meter interface module

### □ MIM-B16

#### 7) Wiring

##### ► Wiring to electricity meter

- Attention must be paid to make polarized connection between an electricity meter and MIM-B16 with correct specifications on wires.

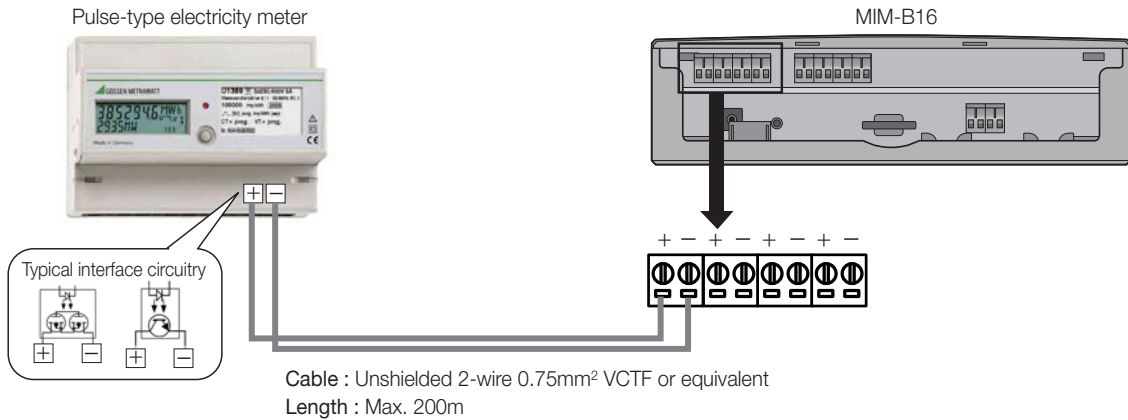

##### ► Wiring to DMS2

- Make sure that communication cable is wired between DMS2 and MIM-B16 with the right polarity.

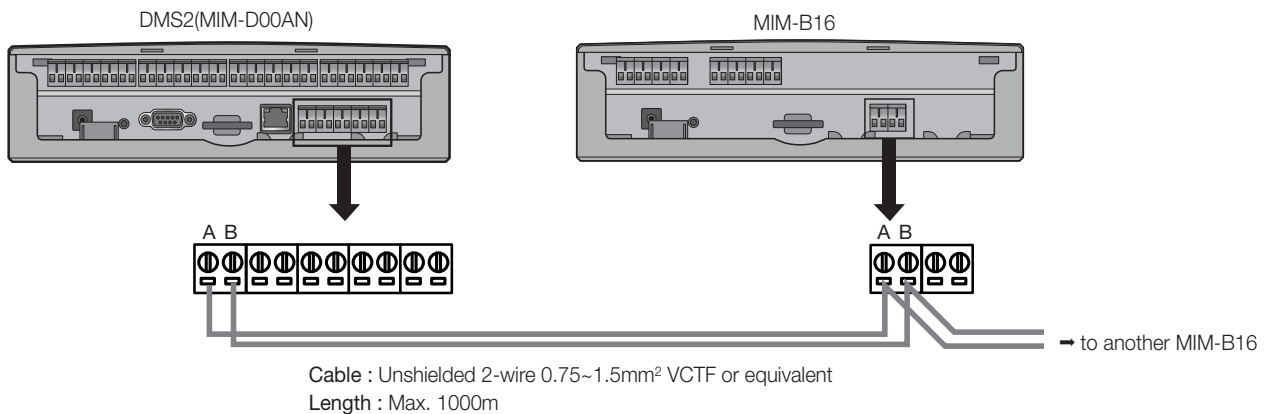

##### ► Caution

- MIM-B16(PIM) should be connected to dedicated channel of DMS2 in advance  
Ex) DMS2 CH1 : PIM + Outdoor unit (X)  
PIM + On/off controller (X)