



VOLTA XS R290 GEN1



EN

TECHNICAL MANUAL

MODEL:

SERVICE CONTACT:

Contents

1. General information	5
1.1. Safety considerations	5
1.2. Disposal	11
2. Heat pump installation	13
2.1. Transport and handling	13
2.2. Dimensions and connections	13
2.3. Unpacking	14
2.4. Assembly and disassembly of the covers	15
2.5. Recommended positioning	15
2.6. Service areas	16
3. Hydraulic installation	18
3.1. General instructions	18
3.2. Brine circuit	18
3.3. Heating / Cooling circuit	19
3.4. DHW circuit	22
3.5. Drain	22
4. Filling and discharge circuits	23
4.1. Filling the production circuit (heating, cooling, DHW and pool)	23
4.2. Filling the brine circuit	23
4.3. Discharging the circuits	24
5. Electrical system	25
5.1. General instructions	25
5.2. Heat pump control power supply	28
5.3. External protections	29
5.4. Outside temperature sensor	29
5.5. External storage systems	29
5.6. External production equipment	29
5.7. DG1 – DG2 Outlet Units	30
5.8. External auxiliary equipment	30
5.9. Alarm signal	30
5.10. Remote control by digital input	30
5.11. Inside environment control	31
5.12. Remote control by BUS	33
5.13. Energy meter	34
6. Start-up	35
7. Technical specifications VOLTA XS R290	36
7.1. Component location	36
7.2. Power circuit diagram	39
7.3. VOLTA XS R290 electrical connection tables	40
7.4. Hydraulic operational area	41
8. Operation map	42
9. Operation curves	43

10. Technical data table..... 44

11. Symbols..... 46

1. General information



- This manual contains the necessary information to install the heat pump. Read this manual carefully before installing the equipment. Keep this manual handy for future reference.

This manual contains two different kinds of warnings that should be heeded.



NOTE

- Indicates a situation that may cause material damage or equipment malfunction. This may also be used to indicate practices that are recommended or not recommended for the equipment.



DANGER!

- **W**arning of imminent or potential danger which, if not avoided, may result in injury or even death. This may also be used to warn of unsafe practices.

VOLTA XS heat pumps are designed to function within heating systems, cooling systems, for the production of domestic hot water (DHW), pool heating or other similar uses. The manufacturer is not responsible for any material damage and/or personal injury resulting from improper use or incorrect installation of the equipment.

The heat pump must be installed by a licensed installer in accordance with applicable local regulations and in accordance with the installation instructions described in this manual.

1.1. Safety considerations

The detailed instructions in this section cover important safety aspects and must therefore be strictly complied with.



DANGER!

- **A**ll the installation and maintenance work described in this manual must be performed by an authorised engineer.
- **D**o not allow children to play with the heat pump.
- **C**hildren should not clean or maintain the heat pump without adult supervision.
- **I**mproper installation or use of the equipment could cause electrocution, short circuits, leakage of working fluids, fire or other personal injuries and/or material damage.
- **I**f you are unsure of the procedures for installation, maintenance or use of the equipment, contact your local dealer or technical support for advice.
- **I**f you detect a malfunction in the unit, contact your local dealer or technical support to answer any questions.
- **W**hen carrying out installation, maintenance or commissioning of the heat pump, always use appropriate personal protective equipment.
- **K**eeep the plastic bags included in the packaging out of the reach of children, as improper use could result in injury caused by asphyxia.

Refrigerant

VOLTA HEAT PUMPS heat pumps may contain different types of refrigerants depending on the model. The refrigerants used by VOLTA HEAT PUMPS are not harmful to the environment as they do not contain chlorine and therefore do not contribute to the destruction of the ozone layer. Refer to the label on your heat pump to identify which refrigerant it contains. You can use the following table to check their flammability and toxicity characteristics.

Refrigerant	GWP	Flammability, see label	
R410A	2088	A1	No
R290	3	A3	

Table 1.1. Flammability and toxicity properties of refrigerants used by VOLTA HEAT PUMPS heat pumps.

Under normal operation of the heat pump the toxicity of the refrigerant is nil and there is no risk of explosion. However, the following precautions should be taken in the event of refrigerant leakage.



- **T**he refrigerant contained inside the heat pump must not be released into the atmosphere as it contributes to global warming (GWP).
- **T**he refrigerant should be recovered for recycling or elimination according to current legislation.
- **D**o not directly touch the area where the leak has occurred, as this could result in severe frostbite injuries.
- **I**n the event of refrigerant leakage, ventilate the area immediately.
- **M**ake sure that the area in which the heat pump is installed is properly ventilated before you open the unit's refrigerant circuit.
- **K**ep the area ventilated while performing maintenance or repair operations.
- **A**nyone who has come into contact with refrigerant vapour must evacuate the area immediately and breathe fresh air.
- **A**1 refrigerants: Direct exposure of the refrigerant to a flame produces toxic gas. However, this gas can be detected by its odour when at concentrations well below the permitted limits.
- **A**2L and A3 refrigerants: Do not allow any source of ignition to come into contact with the refrigerant. When searching for a refrigerant leakage, use means that do not involve a naked flame. If you use an electronic detector, it must be designed to detect the refrigerant used by the unit. Leak detection equipment shall be set at a percentage of the LFL of the refrigerant and shall be calibrated to the refrigerant employed, and the appropriate percentage of gas (25 % maximum) is confirmed. You can also use liquid detectors, but make sure that the detergents in these liquids do not contain Chlorine which can corrode copper piping. Please remember that refrigerants may not give off any odour.

In addition to the above recommendations, please observe the following precautions when carrying out maintenance and repair work.



DANGER!

- **B**efore carrying out any work on the refrigerant circuit, the power supply must be disconnected. If it is absolutely necessary to have an electrical supply to equipment during servicing, then a permanently operating form of leak detection shall be located at the most critical point to warn of a potentially hazardous situation.
- **D**o not pierce or burn any pipes that contain refrigerant until the equipment has been discharged.
- **D**o not carry out maintenance work in enclosed spaces. If necessary, switch off the heat pump and carry out repairs in an adjacent well-ventilated room.
- **A**ll maintenance work must be carried out by an authorised installer in accordance with the applicable local regulations governing work involving refrigerants, and with the instructions contained in this manual. In addition, everyone involved in maintenance work must be aware of the hazards associated with working with refrigerants.
- **F**ollow the maintenance and service guidelines in this manual at all times. If in doubt, contact VOLTA HEAT PUMPS's technical department for assistance.
- **T**he work area must be checked with a refrigerant detector, appropriate to each type of refrigerant, before and during any tasks that require the use of a flame or any other form of heat input to avoid creating explosive atmospheres. To ensure that the gas concentration is a maximum of 25% of the lowest combustible concentration (Lower Flammability Limit, LFL) of the refrigerant used, the leakage detection equipment must be configured and calibrated for the refrigerant used.
- **N**o one carrying out work on a refrigeration system that involves exposing piping should use any source of ignition in such a way as to create a risk of fire or explosion.
- **M**ake sure that CO₂ extinguishing equipment is on hand before starting work involving heat input.
- **C**heck that there are no sources of ignition, including cigarettes, while performing maintenance and repair work on the equipment.
- **B**efore any work is carried out, you must inspect the area around the equipment to ensure that there are no flammable hazards or any risk of ignition. "No smoking" signs shall be put in place.
- **I**f you suspect a leak, all naked flames must be eliminated / extinguished.
- **I**f you discover a refrigerant leak requiring soldering, all refrigerant must be recovered from the system. Do not apply a flame until the circuit is completely empty.
- **M**ake sure that any replacement components in the refrigerant circuit or the heat pump are supplied or approved by VOLTA HEAT PUMPS. Other parts may result in the ignition of refrigerant in the atmosphere from a leak.
- **D**o not apply any permanent inductive or capacitive charge to the heat pump.



- In the presence of a flammable atmosphere, do not activate any component of the heat pump.
- If there is a problem that might compromise safety, do not connect the heat pump to any power supply until it has been satisfactorily resolved. If the problem cannot be corrected immediately, but it is nonetheless necessary to continue with the operation, a suitable temporary solution, agreed with VOLTA HEAT PUMPS's technical department, must be used. This must be reported to the owner of the equipment so that all parties can be informed.
- Never modify safety features such as pressure switches or refrigerant circuit sensors.
- Make sure that the recovery and vacuum equipment is suitable for working with the refrigerant used in the unit, and that it is in good condition.
- At the end of the repair, leave all components (insulation, fasteners and cables) in the same condition as when you found them. In the event of any damage, replace the element in question.
- When starting up the unit, make sure that the condensers are discharged: do this in a safe manner to avoid the possibility of causing sparks.
- Make sure that no active electrical wiring or components are left exposed while charging, recovering, or pumping out the system.
- Make sure that grounding continuity is maintained throughout maintenance and repair work.
- Particular attention shall be paid to the following to ensure that by working on electrical components, the casing is not altered in such a way that the level of protection is affected. This shall include damage to cables, excessive number of connections, terminals not made to original specification, damage to seals, incorrect fitting of glands, etc.
- Intrinsically safe components are the only types that can be worked on while live in the presence of a flammable atmosphere. The test apparatus shall be at the correct rating.

When performing work on a refrigerant circuit, follow these brief guidelines:

1. Remove the refrigerant.
2. Purge with Nitrogen (N₂). This process may need to be repeated several times. Compressed air or oxygen shall not be used for purging refrigerant systems.
3. Vacuum the refrigerant circuit. Ensure that the outlet for the vacuum pump is not close to any potential ignition sources and that ventilation is available.
4. Purge the circuit and spray the area where the opening is to be carried out with Nitrogen (N₂). This process may need to be repeated several times. Compressed air or oxygen shall not be used for purging refrigerant systems.
5. Open the circuit with a blowtorch or by cutting.
6. Carry out the repair work.
7. Close and pressurise with Nitrogen (N₂) to check for the presence of leaks.
8. Vacuum the refrigerant circuit. Ensure that the outlet for the vacuum pump is not close to any potential ignition sources and that ventilation is available.
9. Fill it with the amount of refrigerant indicated on the product label.

Observe the following warnings during the recovery and charging processes:



DANGER!

- **W**hen transferring refrigerant to recovery cylinders, make sure that only suitable refrigerant recovery cylinders are used. Make sure that the correct number of cylinders are available to hold the total system charge. All cylinders to be used are designed for the refrigerant being recovered and labelled for that refrigerant (i.e., special refrigerant recovery cylinders). Cylinders must be complete with a pressure relief valve and associated cut-off valves in good working order. Empty recovery cylinders should be evacuated and, if possible, cooled before recovery takes place.
- **T**he recovery equipment must be in good working order and a set of instructions for the equipment must be to hand. It must be suitable for the recovery of all appropriate refrigerants, including, where applicable, flammable refrigerants. A set of calibrated scales must also be available and in good working order. Hoses must be complete with disconnect couplings free of leaks and in good condition. Before using the recovery machine, check that it is in good working order, that it has been properly maintained and that all associated electrical components are sealed to prevent ignition in the event of refrigerant being released. If in doubt, ask the manufacturer.
- **T**he recovered refrigerant shall be returned to the refrigerant supplier in the correct recovery canister and an appropriate waste transfer note shall be provided. Do not mix refrigerants in recovery units and particularly not in recovery cylinders.
- **I**f you are going to remove a compressor or compressor oil, make sure that it has been evacuated to an acceptable level to ensure that no flammable refrigerant remains within the lubricant. Evacuate the compressor before you return it to the suppliers. To speed up this process, only heat the compressor body by electrical means. When draining oil from a system, do so in a safe manner.
- **M**ake sure that the different refrigerants are not contaminated when using the charging equipment. Keep hoses or lines as short as possible to minimise the amount of refrigerant they contain.
- **K**eeep the recovery tanks in an appropriate position as per the instructions.
- **M**ake sure that the refrigeration system is grounded before charging the system with refrigerant.
- **T**ake great care not to overfill the refrigeration system.
- **T**he system must be tested for leaks when charging has been completed but before start-up. A leak test should be carried out before the equipment is left to operate normally.
- **E**nsure that seals or sealing materials have not degraded to the point that they no longer serve the purpose of preventing the ingress of flammable atmospheres.

Hydraulic installation

Installation and subsequent interventions on the heating, brine or DHW circuits must only be performed by authorised personnel in accordance with applicable local regulations and the instructions provided in this manual.



DANGER!

- Do not touch any of the internal components during or immediately after heat pump operation; this can result in burns caused by cold or heat. If these components need to be touched, allow sufficient time for the temperatures to stabilise and wear protective gloves to avoid injury.

Water quality

Be aware of how the DHW circuits and tank of the heat pump react to corrosion. If you are not sure about the quality of the water available for filling the system, analyse it. In the following tables you can check the water quality level requirements for the production and brine circuit.

Water components	Concentration in mg/l	Water components	Concentration in mg/l
Alkalinity	$\text{HCO}_3^- < 70$	Free carbon dioxide	$\text{CO}_2 < 5$
Sulphur	$\text{SO}_4^{2-} < 70$	Nitrate	$\text{NO}_3^- < 100$
Alkalinity / Sulphur	$\text{HCO}_3^- / \text{SO}_4^{2-} > 1$	Iron	$\text{Fe} < 0.2$
Ammonium	$\text{NH}_4 < 2$	Aluminium	$\text{Al} < 0.2$
Free chlorine	$\text{Cl}_2 < 1$	Manganese	$\text{Mn} < 0.1$
Hydrogen sulphur	$\text{H}_2\text{S} < 0.05$	Chloride	$\text{Cl}^- < 300$

Table 1.2. Concentration limits of water elements for production and brine circuits.

Water properties	Limit values
pH	$7.5 < \text{pH} < 9$
Hardness	$4 < \text{°dH} < 8.5$
Electrical conductivity	$10 < \mu\text{S/cm} < 500$

Table 1.3. Water property limits for production and brine circuits.



DANGER!

- Risk of damage due to unsuitable water.
- Deposits caused by the use of unsuitable water can damage the brine source, the pipes, the heat exchangers and the DHW tank of the heat pump.
- The use of sea water is not permitted.
- The quality of the drinking water must comply with the applicable regional regulations and the instructions in this manual.

Electrical system

Any intervention on the electrical system must only be performed by an authorised electrician in accordance with applicable local regulations and the instructions provided in this manual.

**DANGER!**

- **T**he heat pump has more than one electrical power supply.
- **T**he heat pump must be supplied with an external switch that can cut off all the circuits. VOLTA HEAT PUMPS recommends that an external switch be installed for each of the electrical power sources (control, internal auxiliary equipment and inverter).
- **B**efore performing any operation on the electrical panel, disconnect the power supply.
- **D**uring installation and maintenance of the unit never leave the electrical panel unattended while it is exposed.
- **D**o not touch any component of the electrical panel with wet hands as this could cause an electric shock.
- **I**nstall cables entering the heat pump in such a way that they have no voltage, cannot become corroded, are not affected by vibration and do not touch sharp edges. During repairs or overhauls check for effects of aging or continuous vibration from sources such as the compressor.

1.2. Disposal



- This device should not be treated as household waste.
- At the end of its useful life, dispose of the device properly in accordance with local regulations and in an environmentally friendly way.

The heat pump contains refrigerant. VOLTA HEAT PUMPS uses refrigerants that are not harmful to the environment, but once their useful life cycle is over, the refrigerant must be recovered so that it can be recycled or disposed of in accordance with current regulations.

Please read the following warnings carefully before disposal.

**DANGER!**

- **F**amiliarise yourself with the equipment and its use.
- **E**lectrically isolate the system.
- **B**efore you begin the procedure, make sure that you have the necessary mechanical equipment to handle the refrigerant tank. Also make sure that all necessary personal safety equipment is available and used properly. Finally, make sure that the recovery process is continuously supervised by an authorised person and that the recovery equipment and tanks comply with the appropriate standards.
- **P**ump out the refrigerant system, if possible. If it is not possible to pump it out, create a branch so that the refrigerant can be recovered from different parts of the system.
- **C**heck that the refrigerant tank is on the scale before you start to recover it. Start up the recovery device and recover according to the manufacturer's instructions.
- **D**o not overfill the cylinders (max. 80% of liquid content volume).



-
- **D**o not exceed the maximum permissible working pressure of the cylinders, even temporarily.
-
- **W**hen the cylinders have been correctly filled and the process is complete, close all cut-off valves on the equipment and remove the cylinders and equipment from the installation immediately.
 - **T**he recovered refrigerant must not be poured into any other system before it has been cleaned and inspected.
 - **T**he equipment must be marked to indicate that it has been taken out of operation and emptied of refrigerant. The marking must be dated and signed. Check that the equipment is marked to indicate that it contains flammable refrigerant.
-

2. Heat pump installation

2.1. Transport and handling

The heat pump must be transported vertically and not exposed to adverse weather conditions. It can be lain carefully on its rear side to facilitate transportation to the installation site.



NOTE

- Do not tilt the heat pump more than 45°, since this could impair proper equipment operation.
- Due to its heavy weight, the heat pump should be handled by two workers using a forklift for heavy loads.

2.2. Dimensions and connections

The overall dimensions and hydraulic connections of the VOLTA XS Gen1 heat pumps are described below.

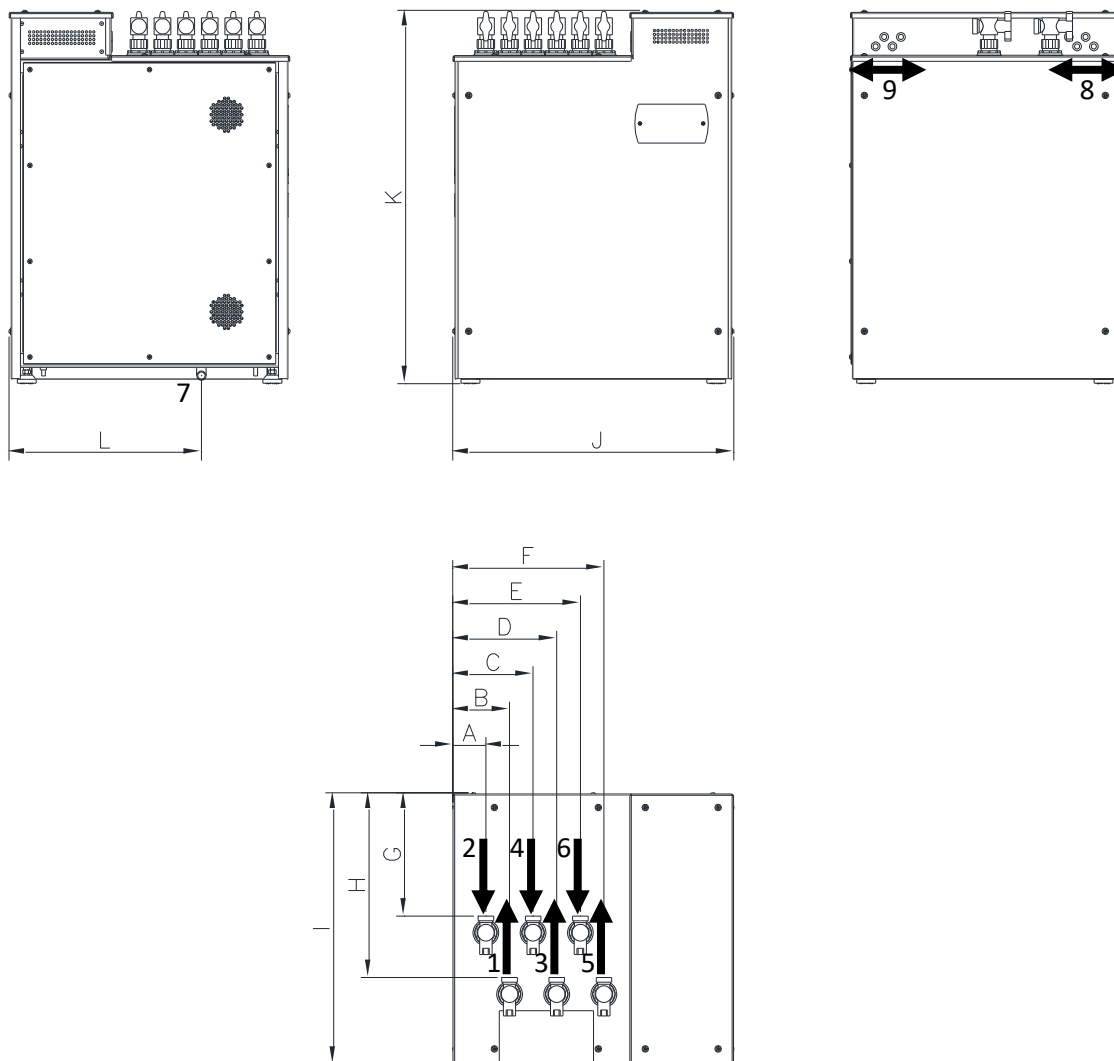

Figure 2.1. Overall dimensions and hydraulic connections of the VOLTA XS model.

No.	Description	VOLTA W-XS-A-6-230 R290
1	Outlet towards space heating/cooling; Male	G1"
2	Inlet from space heating/cooling; Male	G1"
3	Outlet towards collection; Male	G1"
4	Inlet from collection; Male	G1"
5	Outlet towards DHW exchanger; Male	G1"
6	Inlet from DHW exchanger; Male	G1"
7	Drain; Male G3/4"	
8	Power cables inlet	
9	Control cables inlet	

Table 2.1. Hydraulic connections key.

No.	VOLTA W-XS-A-6-230 R290
A	70
B	120
C	170
D	220
E	270
FR	320
G	261
H	391
I	575
J	595
K	790
L	407

Table 2.2. Key to overall dimensions in mm.

The factory installation is prepared for connection at the top.

2.3. Unpacking

To unpack the heat pump, remove the wooden box carefully, remove the pallet anchoring screws and perform a check to make sure the heat pump has not been damaged during transportation.

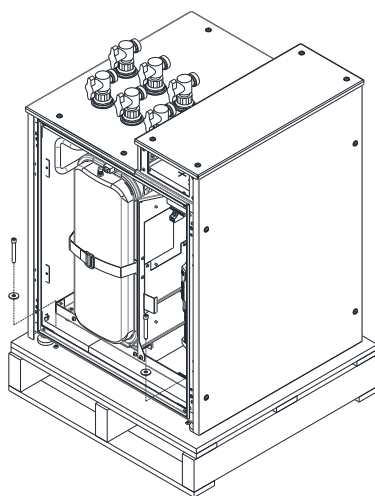

Figure 2.2. Removing the screws fastening the heat pump to the pallet.

2.4. Assembly and disassembly of the covers

A 4 mm Allen wrench is needed to assemble and disassemble the covers.

VOLTA XS Models

1. Disassemble the top cover. Remove the screws located at the rear and pull the cover upwards.
2. Disassemble the front cover. Remove the screws located at the upper part and pull the cover upwards.
3. Disassemble the side covers. Loosen the screws located at the front and rear and on the top, and remove the cover.
4. Once the covers have been removed, the acoustic insulation panels can be removed by pulling them outwards.

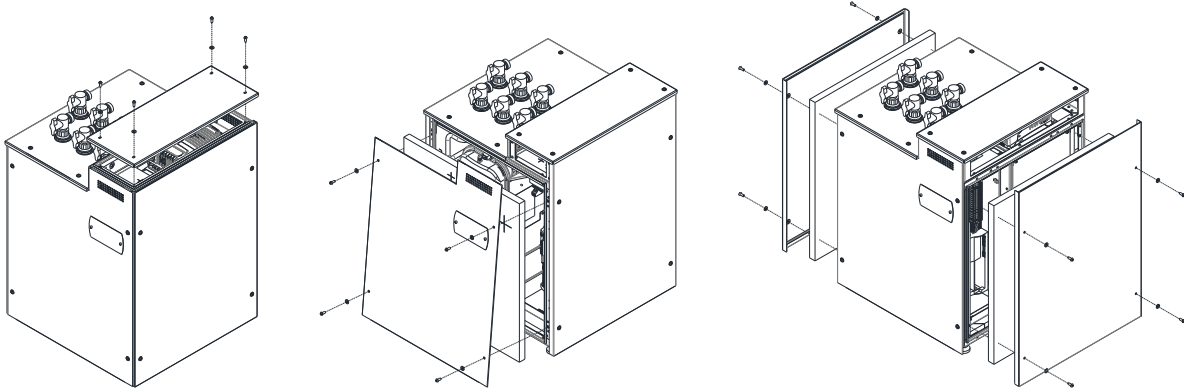

Figure 2.3. Disassembly of the covers of VOLTA XS models



NOTE

- During cover disassembly, take care to remove the control panel cable without damaging it.

2.5. Recommended positioning

Choose a dry place where there is no risk of frost. Avoid installation against bedroom walls or walls of other rooms where noise emissions can be annoying. If possible, install the heat pump with the rear part pointed toward an exterior wall. Avoid installation near a corner, since this can amplify noise emission levels.

The heat pump should be installed on a stable base that can support the total weight of the equipment and the operating fluids in its interior. Use the adjustable legs to compensate for possible irregularities on the supporting surface.

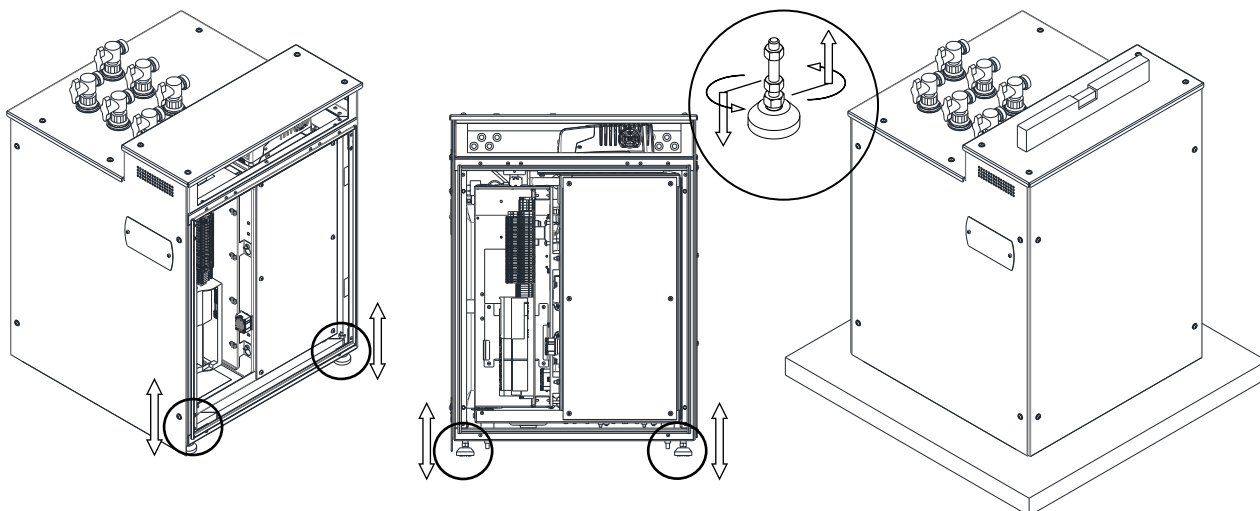

Figure 2.4. Positioning and levelling the heat pump



- **W**arning: VOLTA XS heat pumps have an IP20 protection rating. Their installation in damp environments such as laundries or saunas, etc. is therefore prohibited.
- **T**he heat pump must be stored in a room where there are no sources of ignition in continuous operation (e.g., naked flames, a working gas appliance or a working electric heater).

2.6. Service areas

This heat pump model can be installed inside a cabinet. Access to the front cover must be allowed in order to access the inside of the unit in the event of a fault. For cabinet mounting, two rubber plugs, included in the spare parts box, must be fitted to ensure that there is a 20mm gap between the rear of the unit and the bottom of the cabinet.

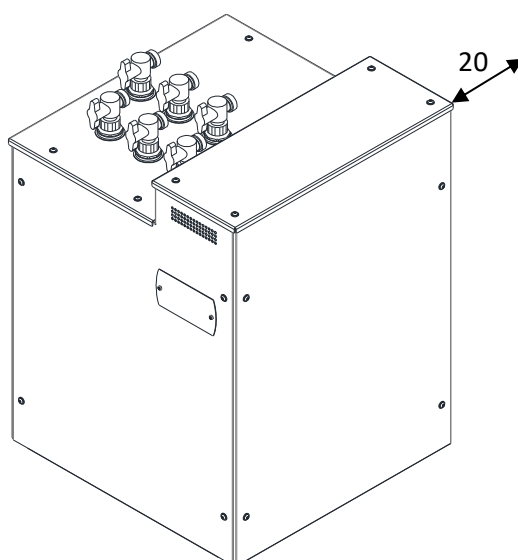

Figure 2.5. Recommended minimum service areas around the heat pump for enclosure mounting (dimensions in mm).



- The cabinet where the equipment is located must be properly ventilated.
- The cabinet must have an opening at the bottom to allow gas to escape in the event of a leak.



- It is recommended that the room where the heat pump is installed is ventilated to the outside.

It is also possible to install this heat pump inside a room without the need to be inside a cabinet. The recommended minimum clearances around the heat pump to facilitate installation, commissioning and maintenance work are given below.

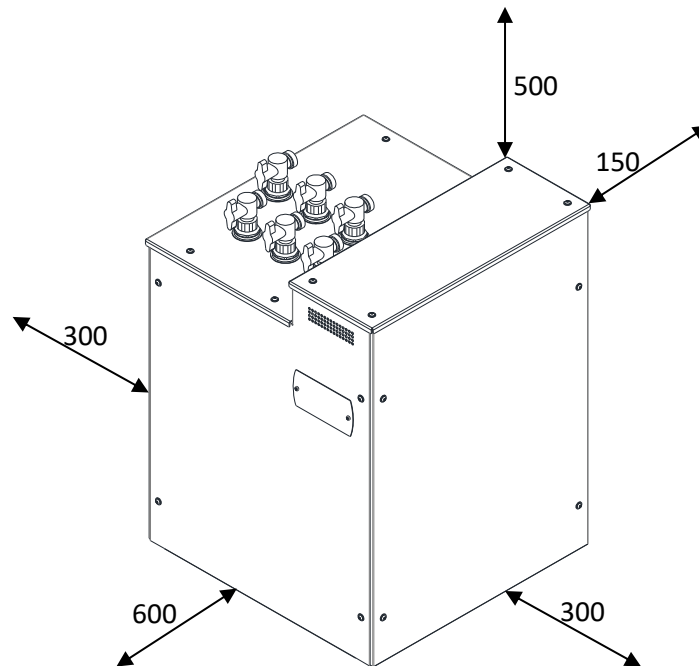

Figure 2.6. Minimum recommended service areas around the heat pump (amounts in mm)



- Do not cover the ventilation ducts of the heat pumps, there may be a risk of components breaking and causing injury and/or material damage.



- Pay special attention, both when designing the piping layout and when positioning the heat pump, to allow easy access to the cover hardware and convenient access to the internal components of the heat pump.
- Consider the extraction system (pipe passages, elbows) when positioning the heat pump, especially with the minimum distance from the rear side.

3. Hydraulic installation



NOTE

- The installation schemes included from here on should be considered simply as a guide.
- The design of the hydraulic installation must be performed by qualified personnel and in accordance with applicable local regulations.
- The design of the hydraulic system must ensure at all times the minimum required flow through the heat pump, otherwise, could cause malfunction of the equipment and even rupture.

3.1. General instructions

The following recommendations should be taken into consideration for proper hydraulic installation.

- Avoid excessive strain between the pipes and the heat pump connections to prevent leaks and/or transmission of vibrations. Flexible hoses should be used for the heat pump wiring.
- Install cut-off valves at all the hydraulic connections to facilitate future maintenance tasks.
- Install traps at all the installation points where air pockets can form.
- Place heat insulation on all circuit pipes to prevent unnecessary heat loss. Pay special attention to the heating insulation on the brine circuit pipes, since these can reach temperatures below 0°C, causing condensation and/or frost.



DANGER!

- **D**uring installation work on the hydraulic circuits, take special care to prevent liquid from spilling on the internal electrical heat pump components, which could cause personal injury due to electrocution and/or poor equipment operation.
- **D**o not install components that might cover the inlet or outlet of the safety valves; this could lead to a risk of some of its components breaking and cause injuries and/or material damage.

3.2. Brine circuit

The VOLTA XS heat pumps can be used with horizontal or vertical (A) geothermal brine systems or by using groundwater (B).



DANGER!

- **C**arefully check the antifreeze concentration of the working fluid. Do not use automatic fill valves or other items that can change the concentration of the working fluid. Inadequate concentration of the working fluid could cause malfunction of the equipment and even rupture.

Geothermal brine systems

Brine systems with more than one circuit must be connected in parallel, so the flow rate through each one is similar.

Groundwater brine systems

Groundwater brine systems must use a midway exchanger to prevent the heat pump evaporator from corrosion, freezing or getting dirty.

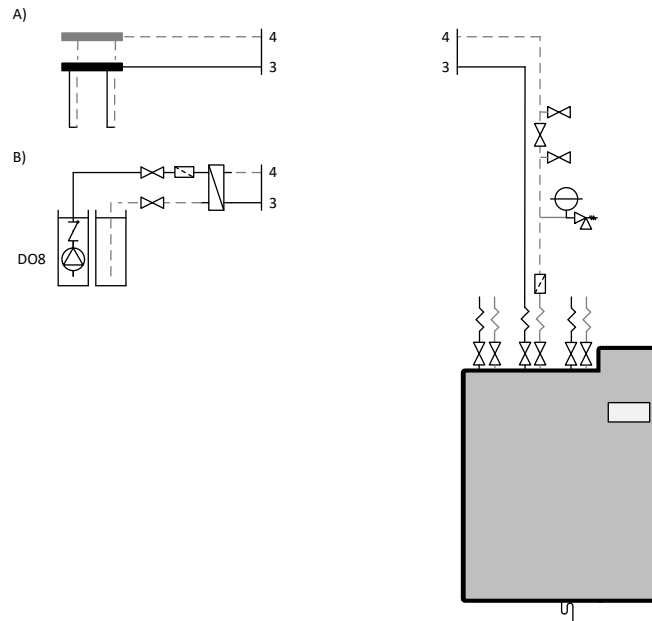

Figure 3.1. Brine circuit connection options

Integrated components

The following brine circuit components are included within the heat pump.

- Variable speed and high efficiency outlet pump (energy class A).
- Safety valve tared to a 6 bar gauge (600 kPa).
- Drain valve.

Installation instructions

Follow the instructions below to wire the brine circuit.

- Install the necessary components to carry out the filling/discharge of the inlet piping.
- Install a particulate filter in the return pipe with a mesh size no greater than 1 mm. It is recommended to install cut-off valves immediately before and after the filter to make it easier to clean or replace.
- Check that the volume of the expansion vessel integrated in the heat pump is capable of absorbing any overpressures from the circuit. If this volume is not enough, install a supplementary external expansion vessel.
- If necessary, adjust the pressure of the expansion vessel integrated in the heat pump to guarantee that the circuit remains pressurised at all points.
- The pressure of the brine circuit must have a value of between 0.7 and 6 bar gauge (70 and 600 kPa).
- Use a working fluid with a freezing point of at least 10°C below the minimum nominal working temperature of the equipment.
- Configure the equipment with a protection of at least 5°C above the freezing temperature of the working fluid.

3.3. Heating / Cooling circuit

The VOLTA XS heat pumps can be connected to various types of heating / cooling systems, both directly and by separating buffer storage tanks. On the other hand, these enable control over several devices that are external to the heating / cooling system directly from the heat pump's electrical panel.

Heating / cooling system

VOLTA XS heat pumps are designed for use with underfloor heating systems, low temperature radiators or convectors, etc. They are not recommended for use in heating systems that require higher temperatures. For nominal operating temperatures, please refer to the products' technical tables.

VOLTA XS heat pumps can be used with cooling systems such as convectors and underfloor cooling systems.

Special care should be taken in the design and control in installations with underfloor cooling, to prevent problems of condensation on floors.

The models that are not equipped with integrated free cooling allow control of external free cooling equipment.

Direct installation

In simple heating / cooling systems, VOLTA XS heat pumps can be installed directly into the distribution system, in systems with underfloor heating, low temperature radiators and convectors.

This configuration makes it possible to simplify the hydraulic installation, reduce costs and space, while optimizing the energy efficiency of the equipment. However, the design of the hydraulic installation must guarantee the minimum required flow at all times through the heat pump. For this, the necessary elements must be planned to protect the heat pump in the event of a low flow situation in the system. For this, the installation can be planned to operate with at least one of the emission circuits open continuously. If all the emission circuits can be closed, it is recommended to install a differential pressure valve between the outlet and inlet pipes of the heat pump. Other solutions can also be considered, such as the installation of a hydraulic separator between the heat pump and the emission system, as long as the minimum required flow is guaranteed (see section 10).

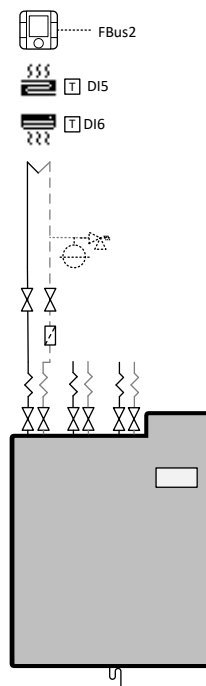

Figure 3.2. Single zone wiring scheme directly to the heating / cooling system

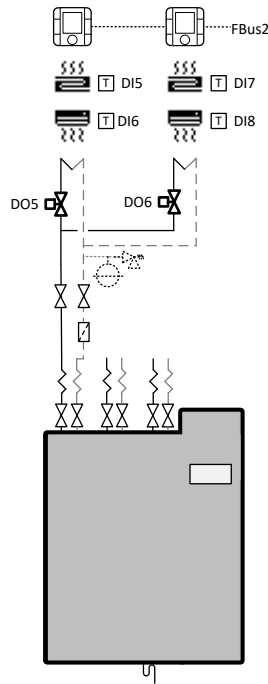

Figure 3.3. Dual zone wiring scheme directly to the heating / cooling system

Outlet units

These make possible to manage different outlet temperatures. This is done by managing two direct outlet units. Please refer to section 5.7. The combined outlet units have to use modulating 3-way valves with an analogue signal of 0-10Vdc. Each outlet unit has independent terminals for heating and cooling demands. These signals must be supplied with 24Vac voltage.

Integrated components

The following heating / cooling circuit components are included within the heat pump.

- Variable speed and high efficiency pump (energy class A).
- Expansion vessel with a capacity of 7 litres, with pre-adjusted pressure of 1.3 bar (130 kPa).
- Safety valve tared to a 3 bar gauge (300 kPa).
- Drain valve.

Installation instructions

- Follow the instructions below to wire the heating / cooling circuit.
- Install a particulate filter in the return pipe with a mesh size no greater than 1 mm. It is recommended to install cut-off valves immediately before and after the filter to make it easier to clean or replace.
- Check that the volume of the expansion vessel integrated in the heat pump is capable of absorbing any overpressures from the circuit. If this volume is not enough, install a supplementary external expansion vessel.
- If necessary, adjust the pressure of the expansion vessel integrated in the heat pump to guarantee that the circuit remains pressurised at all points.
- If there is an auxiliary system integrated in the heating storage tank, install a safety valve to protect it from any overpressures.
- The pressure of the heating / cooling circuit must have a value of between 0.7 and 2 bar gauge (70 and 200 kPa).

3.4. DHW circuit

The VOLTA XS heat pumps are designed to be used with external storage systems with a midway heat exchanger that can be either internal or external.

Auxiliary equipment integrated in the DHW storage tank

This is used to control a support system integrated in the DHW storage tank. This can be used as support to reach higher temperatures during normal production, to carry out legionella protection programs or as emergency equipment.

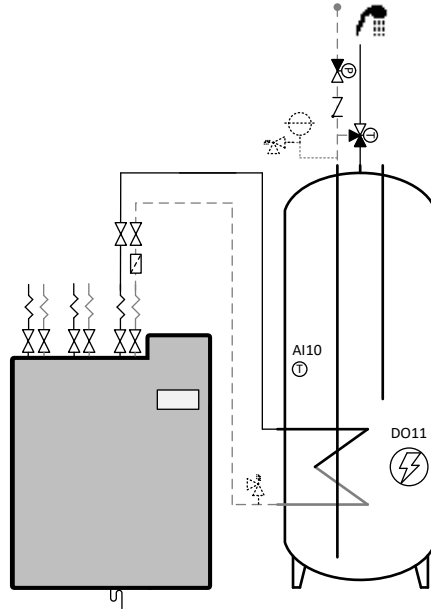

Figure 3.4. Wiring scheme of the DHW circuit

Installation instructions

Follow the instructions below to wire the DHW circuit.

- In the VOLTA XS models, install a particulate filter in the return pipe to the heat pump with a mesh size no greater than 1 mm. It is recommended to install cut-off valves immediately before and after the filter to make it easier to clean or replace.
- The DHW tank is permanently connected to the tap water supply.
- Install a check valve at the tap water inlet to prevent the possible return of hot water from the mains.
- A safety group (expansion vessel + safety valve) must be installed at the tap water inlet to prevent possible overpressure in the DHW storage tank.
- If there is a risk of scalding, a thermostatic mixing valve should be installed at the DHW outlet.
- If the maximum system pressure can exceed 5 bar, it is recommended to install a pressure reducing valve in the mains inlet to prevent overpressure in the storage tank.
- If there is an auxiliary system integrated in the DHW storage tank, install a safety valve in the production circuit inlet to protect it from any overpressures.

3.5. Drain

Condensation may occur on certain internal heat pump components during normal operation. On the other hand, antifreeze mixture or water may spill from the heat pump's internal safety valves due to eventual circuit overpressure.

There is a drain connection at the rear of the heat pump to evacuate these liquids.

4. Filling and discharge circuits



DANGER!

- During filling work on the hydraulic circuits, take special care to prevent liquid from spilling on the internal electrical heat pump components, which could cause personal injury due to electrocution and/or poor equipment operation.

4.1. Filling the production circuit (heating, cooling, DHW and pool)

The heat pump is equipped with internal filling / discharge valves for the production circuit. It is recommended to use these valves to ensure that the internal circuits are completely bled. Take the following steps to fill the circuit.

1. Open all the valves of the production circuits.
2. Fill the circuit through the filling valve until the target pressure is reached. Make sure that the pressure does not exceed 3 bar (pressure gauge) under any circumstance.
3. Remove the air from the circuit using the traps installed for that purpose.
4. Check the circuit pressure and repeat the filling process if necessary.

4.2. Filling the brine circuit

The brine system temperature can fall below 0°C, so a mixture of water/antifreeze agent must be used. It is recommended to use propylene glycol as an antifreeze additive or ethylene glycol with a corrosion inhibitor. Please check local regulations before using any type of antifreeze mixture.

When preparing the mixture, be careful to calculate the volume of antifreeze agent necessary to reach the desired degree of antifreeze protection. It is recommended to use a mixture with a freezing point at least 10°C below the nominal minimum temperature.

Brine circuit filling should be done with the filling unit installed in the return pipe and an external circulation pump, taking the following steps.

1. Prepare the appropriate proportions of antifreeze mixture in external tank A.
2. Connect the external recirculation pump outlet to valve D.
3. Connect a transparent hose from valve E to antifreeze mixture tank A.
4. Close valve C and open filling valves D and E.
5. Start the external recirculation pump and keep it running until the return is completely free of air and the antifreeze mixture is mixed perfectly.
6. Open valve C and keep the external pump connected to remove the air between valves D and E.
7. Close valve E and pressurise the circuit to target pressure. Make sure that the pressure does not exceed 6 bar (pressure gauge) under any circumstance.
8. Close valve D.

After completing the brine circuit filling process, it is recommended to check the concentration of antifreeze mixture again using a refractometer.

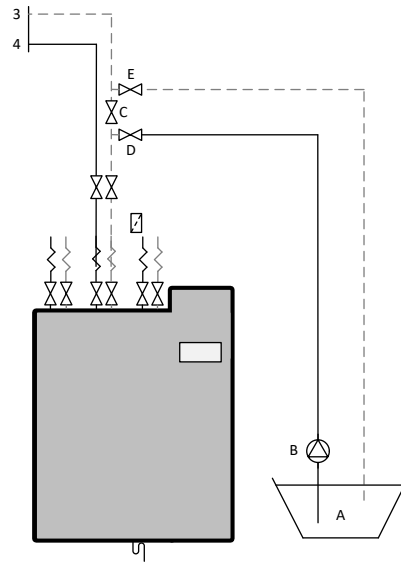

Figure 4.1. Filling the brine circuit

4.3. Discharging the circuits

The heat pump is equipped with internal drain valves that ensure complete discharge of the various internal circuits.

5. Electrical system



- **B**efore performing any operation on the electrical panel, disconnect the power supply.
- **R**emember that the heat pump has more than one electrical power supply.
- **V**OLTA HEAT PUMPS recommends that an external switch be installed for each of the electrical power sources (control, internal auxiliary equipment and inverter).
- **A**ny intervention on the electrical system must only be performed by an authorised electrician in accordance with applicable local regulations and the instructions provided in this manual.
- **T**he cables used to connect the heat pump must comply with applicable national regulations.
- **I**nstall cables entering the heat pump in such a way that they have no voltage, cannot become corroded, are not affected by vibration and do not touch sharp edges.
- **I**nstall power cables so that the ground cable is at least 50mm longer than the rest of the cables, to ensure that it is the last cable to be disconnected in case of accidental disconnection.
- **I**f the power cord is damaged, it must be replaced by an authorized VOLTA HEAT PUMPS service technician to avoid risks.

5.1. General instructions

The locations of the main electrical panel components are shown below.

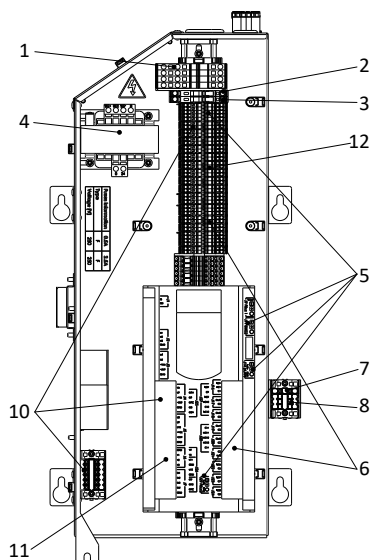

1. Power supply
2. Transformer fuse
- 3 Control fuse
4. Transformer 24Vac
5. Bus ports: BMS2, pLAN y FBus2
6. DOxx: Digital outputs
7. V4V: Cycle inversion valve activation signal
8. Pumps activation: Pump activation signal
9. pCO OEM+ controller
10. AIxx: Analogic inputs
11. AOxx: Analogic outputs
12. DIxx: Digital inputs

Figure 5.1. Location of the components in the VOLTA XS electrical panel Block I.

Several installation devices are controlled from the heat pump electrical panel. Some are internal and other are installed externally. The internal components are connected to the electrical panel in the factory. Depending on the installation that the heat pump is going to be connected to, in addition to the power supply, it may be necessary to connect various temperature sensors (analogue inputs AIxx), control signals from thermostats or other external equipment (digital inputs DIxx) on/off switching of pumps and/or valves (digital outputs DOxx) or regulation of pumps and/or valves (analogue outputs AOxx).

The figure below shows a sample installation with the options for connecting external components to the heat pump.

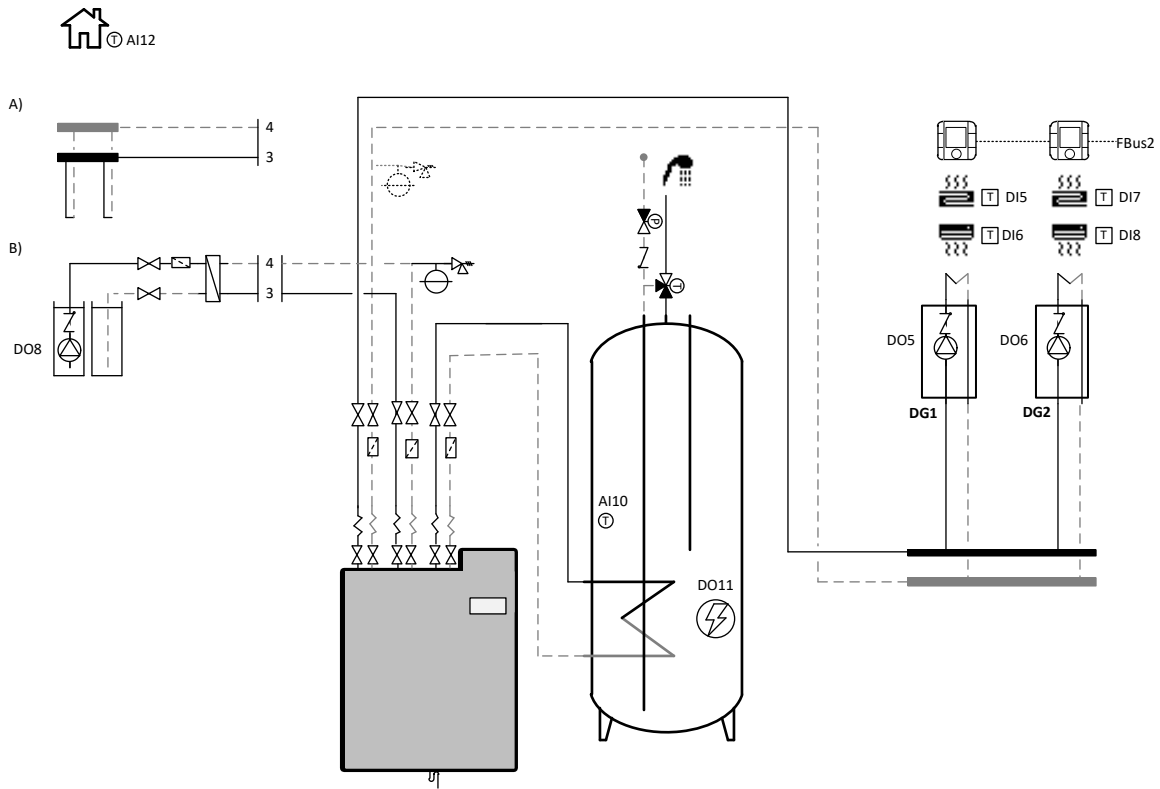

Figure 5.2. General scheme of the heat pump's electrical connections Example shown is an VOLTA XS model.

Analog inputs (AIxx)

These terminals are used to connect external temperature sensors. Only passive NTC temperature sensors can be connected, so cable connection polarity is not important.

If necessary, use extension cables with a maximum length of 50 m and a minimum diameter of 0.75 mm². For greater lengths (up to 120 m) it is recommended to use cable with a section of 1.5 mm².



NOTE

- Use original temperature sensors only; other types of components could cause poor heat pump operation and/or cause heat pump component breakdowns.

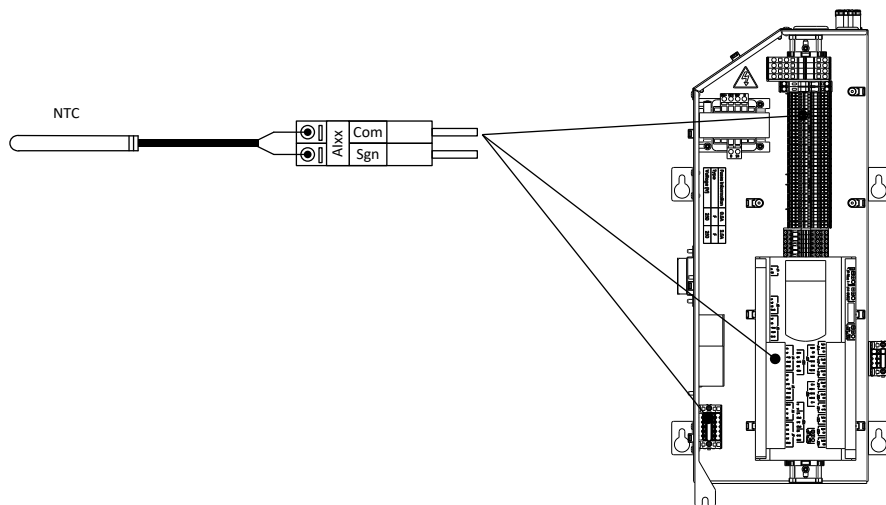

Figure 5.3. Example of temperature sensor connections

Digital control inputs (DIxx)

Digital signals from thermostats or other external devices can be connected to these terminals to control heat pump production functions.



- Take special care with the working voltage of each digital input; improper handling could cause poor heat pump operation and/or heat pump component breakdowns. Some digital inputs require voltage-free signals, while others require 24Vac signals. 24Vac signals are sent from their own terminal block strip.
- Do not mix voltage-free and 24Vac signals.

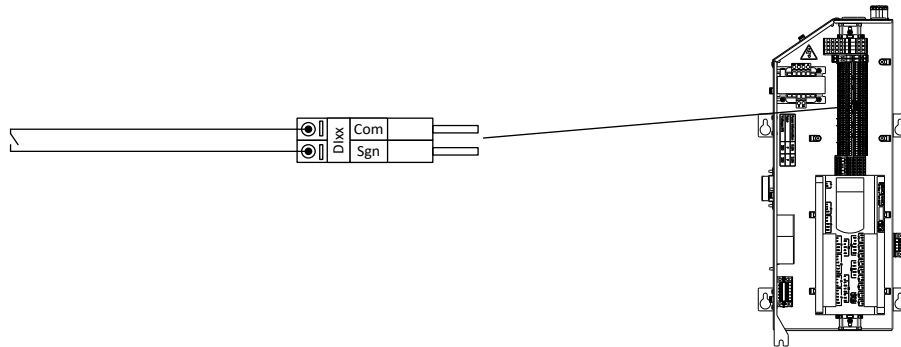

Figure 5.4. Example of voltage-free digital input connections



- You can connect external units to 24Vac directly from the heat pump; the total connected units must not exceed 36VA or 1.5A. If you ignore these ranges, the heat pump may malfunction and/or cause a component to break.

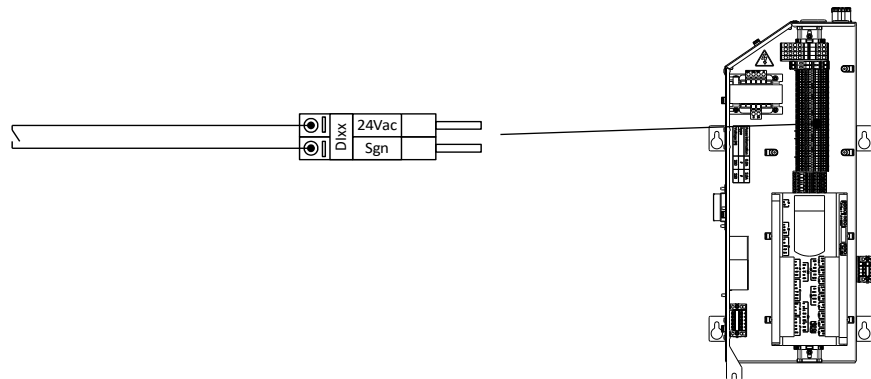

Figure 5.5. Example of digital input connection with 24Vac voltage

Digital outputs to relay (DOxx)

These terminals provide 230Vac activation signals for various external components, such as outlet units, open / close 3-way valves, external auxiliary equipment, etc. The connectors used for valve control allow connection of any type of 2-point control valve, as long as it has a single-phase 230Vac power supply.



- Pay special attention to the maximum consumption allowed by each connector. Use an intermediate relay for the connection, if necessary.

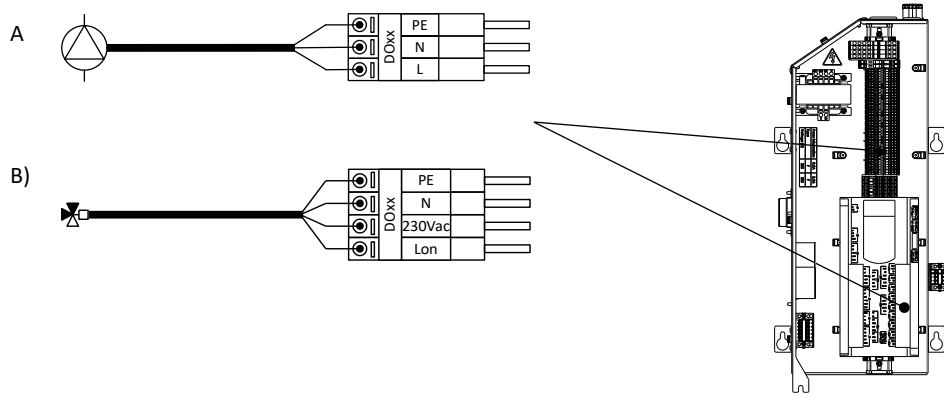



Figure 5.6. Example of digital outputs to relay for A) circulator pumps and B) open / close 3-way valves

ModBus RS485 (FBus2) Communication Port

Internal terminals with thT bus communication data can be connected to this terminal.

5.2. Heat pump control power supply

The VOLTA HEAT PUMPS heat pump requires 1/N/PE 230V / 50-60 Hz.

Heat pumps must be powered via an automatic external differential switch which switches off all the circuits and which detects at least alternating or pulsating leakage currents with or without a continuous component, i.e., a type A or A HI component (). In addition to the differential switch mentioned above, the heat pump must be protected by an external thermal-magnetic switch. Shown below are the recommended cable diameters for each heat pump model and the recommended range of external electric thermal-magnetic protection. Maximum heat pump electrical consumption can vary widely depending on working conditions; for more information, please refer to the Technical Service Manual.

Model	Electrical power power supply	Cable section	Maximum current
VOLTA W-XS-A-6-230 R290	Single phase	2.5 mm ²	13 A

Table 5.1. Dimensioning of the power cable and the external switch.

To carry out the electrical installation, insert the power cable through the rear cover of the heat pump and pass it to the bottom left part of the heat pump. Continue by connecting the cables to the power terminal block of the heat pump, as described below.

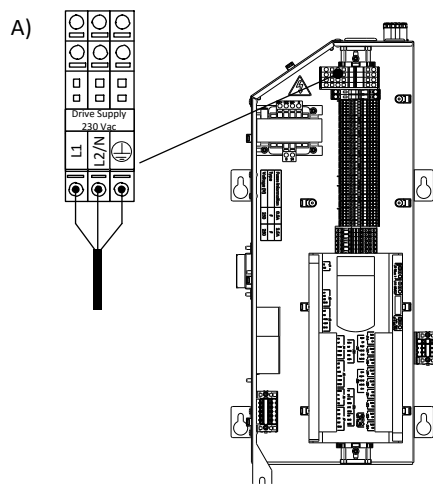

Figure 5.7. Power supply connection scheme in the A) single phase.

5.3. External protections

It is equipped with a connector that can be connected to various types of external mechanical protections, such as flow switches, pressure switches, thermostats, etc.

The ESS connector is used to wire these protections. The external protection devices are powered from the heat pump connector and should have a cut-off capacity of at least 200mA/230Vac.

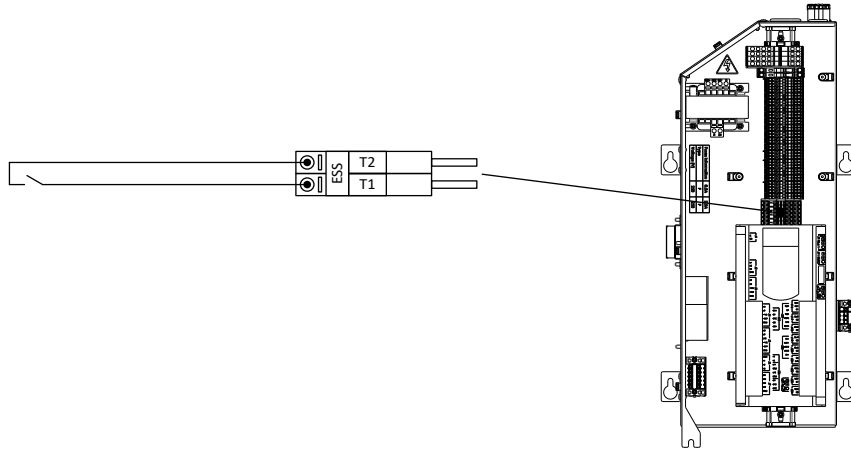

Figure 5.8. Connection scheme of the external protection devices

5.4. Outside temperature sensor

The outside temperature sensor, supplied with the heat pump, has to be installed for the heat pump to work properly.

The VOLTA XS range is equipped with an NTC outdoor temperature sensor.

When installing the sensor, bear the following indications in mind:

- Install the outside sensor in a well-ventilated area, but protected from wind and rain.
- Do not install the outside sensor at a distance of less than 1 m from windows or doors to avoid the effect of possible currents of warm air.
- It is recommended that you use a shielded 2-pole cable to prevent interferences.

Description	Signal	Type	Connector
External sensor temperature	Analog input	NTC 10K 25 °C sensor	AI11

Table 5.2. Connection terminals for external sensor temperature.

5.5. External storage systems

These can be used to control DHW storage, heating and cooling temperatures using temperature sensors.

Description	Signal	Type	Connector
DHW inter-storage tank	Analog input	NTC 10K 25 °C sensor	AI10

Table 5.3. Connection terminals for external accumulation system.

5.6. External production equipment

These are used to control production equipment handling of the various services, such as bypass valves or circulator pumps.

Description	Signal	Type	Connector
Active cooling production	Digital output	Activation 230Vac / 2A maximum	DO13
DHW production	Digital output	Activation 230Vac / 2A maximum	DO3

Table 5.4. Connection terminals for external production equipment.

5.7. DG1 – DG2 Outlet Units

The heat pump can control two direct outlet units (DG1 and DG2). Unit activation can be controlled according to heating or cooling demand. In addition, the units with mixture can measure the unit's outlet temperature and generate a regulation signal for the 3-way modulating valve.

Description	Signal	Type	Connector
DG1 direct unit	Digital output	Activation 230Vac / 2A maximum	DO5
DG2 direct unit	Digital output	Activation 230Vac / 2A maximum	DO6

Table 5.5. Connection terminals for outlet units.



NOTE

- You can connect external units to 24Vac directly from the heat pump; remember that the total connected units must not exceed 36VA or 1.5A. If you ignore these ranges, the heat pump may malfunction and/or cause a component to break.

5.8. External auxiliary equipment

This is used to control the activation of the auxiliary equipment integrated in the DHW heating buffer storage tanks via outputs to relays. They are also used to control activation of the all / nothing external auxiliary boiler. If modulating boilers are installed, it is also used to control the temperature downstream from the boiler, so the heat pump and the boiler can function simultaneously.

Description	Signal	Type	Connector
DHW inter-storage tank auxiliary equipment	Digital output	Activation 230Vac / 2A maximum	DO11

Table 5.6. Auxiliary equipment connection terminals.

5.9. Alarm signal

If the heat pump cannot start up the compressor because of an active alarm, the heat pump will generate an alarm signal.

Description	Signal	Type	Connector
Alarm signal	Relay digital output	Activation 230Vac / 2A maximum	DO9

Table 5.7. Connection terminals for alarm signal.

5.10. Remote control by digital input

The heat pump is equipped with digital inputs for remote control of production services, EVU control and SG control modes.

Description	Signal	Type	Connector
Control of electrical consumption (EVU)	Digital input	Voltage-free (0V)	Configurable (DI1/DI2/DI3)
1 SG signal	Digital input	Voltage-free (0V)	Configurable (DI1/DI2/DI3)
2 SG signal	Digital input	Voltage-free (0V)	Configurable (DI1/DI2/DI3)
WINTER / SUMMER program selection	Digital input	Voltage-free (0V)	Configurable (DI1/DI2/DI3)
Enable / disable DHW production	Digital input	Voltage-free (0V)	Configurable (DI1/DI2/DI3)

Table 5.8. Connection terminals for digital inputs that control service production, EVU and SG modes.



NOTE

- Activation of the SG mode control is incompatible with EVU and only allows you to assign the remaining digital input to WINTER / SUMMER remote programme selection or DHW production.

EVU (production control with compressor and electric resistors)

Enables / disables energy production with both the compressor and the auxiliary equipment. In any event, circulator pumps, valves and other components can be activated to consume energy from the storage systems.

SMART GRID

Enables / disables the SG states of the heat pump. Depending on the value of the digital inputs, there are four SG operating statuses:

SG1 [0 0] (Normal state): The heat pump is operating normally, as per its configuration.

SG2 [0 1] (Reduced tariff): As we are in a reduced tariff period, we will take advantage of the lower price of electricity to use the pump to produce heat or cold.

SG3 [1 0] (Block status): Signal for compressor blocking to the heat pump.

SG4 [1 1] (Forced state): The heat pump will force the maximum possible consumption in the installation to help balance the network.

These external signals can be sent by the electricity company itself to endeavour to keep the distribution network balanced at all times.

Remote WINTER / SUMMER program selection

Used for remote selection of the heat pump operation program.

DHW production

Enables / disables the DHW production function. If the function is enabled, DHW production is governed by the DHW configuration in the heat pump controller.

Pool production

Activates / deactivates pool production demand. If the signal is requested, pool production is governed by the pool configuration in the heat pump controller.

5.11. Inside environment control

The heating and cooling functions can be controlled by digital signals from relay thermostats, by interior terminals with thT bus communication, by a combination of both or even not using any interior control terminal.

Relay thermostats

Each outlet unit, from DG1 to SG4, has two 24Vac digital signals to activate heating or cooling demands from the interior thermostats or other external control devices.

Description	Signal	Type	Connector
DG1 direct unit heating request	Digital input	24Vac signal	DI5
DG1 direct unit cooling request	Digital input	24Vac signal	DI6
DG2 direct unit heating request	Digital input	24Vac signal	DI7
DG2 direct unit cooling request	Digital input	24Vac signal	DI8

Table 5.9. Connection terminals for digital inputs that control outlet units DG1 – DG2.

A single thermostat or several thermostats connected in parallel can be used for each outlet unit, as shown below.

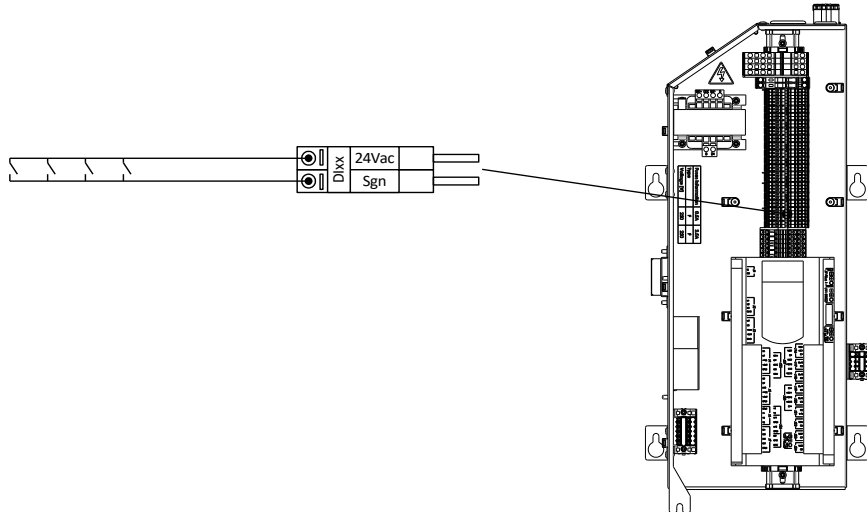

Figure 5.9. Example of connection of several thermostats in parallel

thT bus terminals

In addition to digital input control (interior thermostats) interior terminals with thT data bus communication can also be used. These terminals capture the inside temperature and humidity of the area associated with each outlet unit, DG1 – SG4, using a serial cable over a Modbus protocol. They also have a digital output to control a valve for the area. A single thT terminal can be connected per outlet unit.

Read the assembly instructions carefully before installing the terminals.

description	Signal	Connector
thT terminal communication bus	ModBus RS485	FBus2

Table 5.10. Data bus connection terminals for the thT terminals.

Follow the recommendations below to connect the thT terminals to the heat pump.

- Use a three-pole, shielded AWG 20-22 cable for the connection.
- Connect the terminals in series for installations with more than one terminal in the network. The maximum length of the circuit assembly should not exceed 500 metres. For connection networks with more than two thTs, it is necessary to install a 120 Ohm heater between Rx+/Tx+ and Rx-/Tx- in the first and last terminal to prevent possible communication problems.
- Configure the terminal address according to the settings of the controller following the steps described in the thT terminal manual.

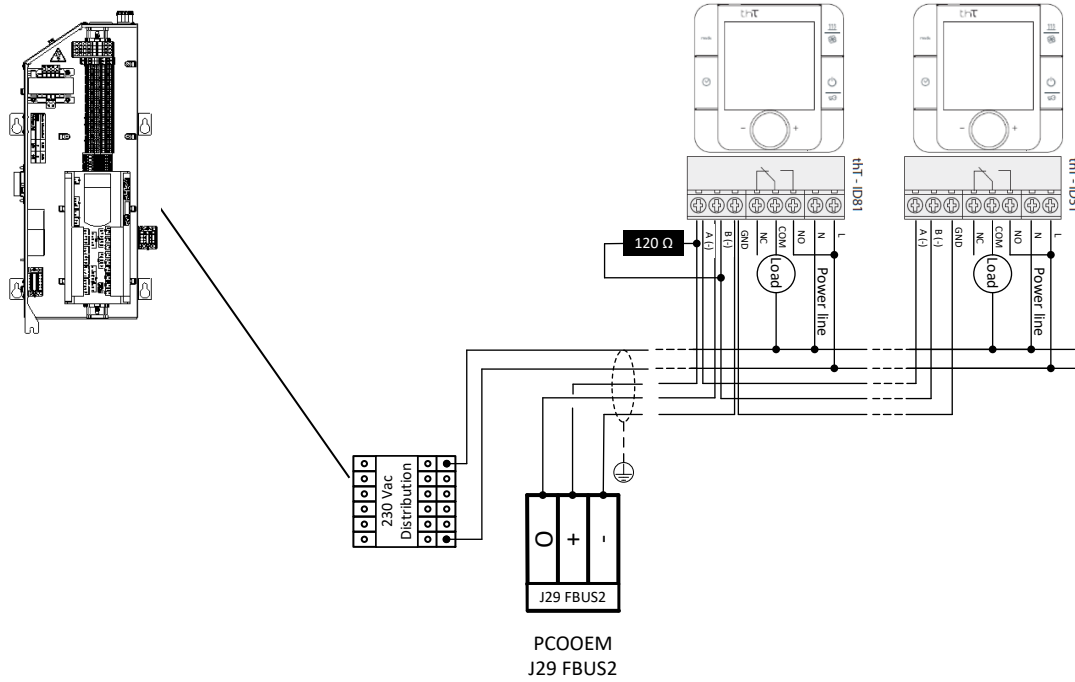

Figure 5.10. Example of connection of thT terminals

Installation without interior terminals

The VOLTA XS heat pumps can also be used in installations that do not have any type of interior terminal to generate request signals. In these cases, a continuous request can be imposed at the digital input of the unit to activate by selecting the appropriate control logic in the controller. As a result, the heat pump will run the start / stop cycles according to the temperature control of the circuit and the outside cut-off temperatures of each service.

5.12. Remote control by BUS

The heat pump allows MODBUS communication. Signals can be sent to switch the heat pump on and off, activate the demand for DHW, pool or heating or cooling services for each configured outlet unit and vary the setpoints for DHW, pool and for both heating and cooling in each unit.

Description	Signal	Connector
MODBUS read and write	ModBus RS485	BMS2

Table 5.11. Read and write data bus connection terminals.

Follow the recommendations below for connecting the converters.

- Use a three-pole, shielded AWG 20-22 cable for the connection.
- For installations with more than one heat pump, connect the terminals in series. The maximum length of the circuit assembly should not exceed 500 metres.
- Configure the BMS2 terminal address on the controller following the steps laid out in the technical service manual.

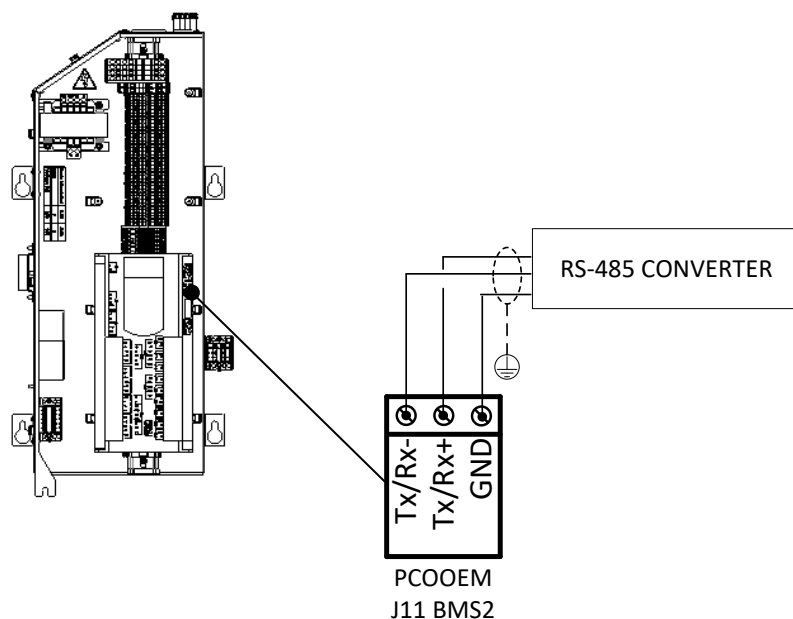

Figure 5.11. Example shown: an RS-485 converter connection for read write data on the heat pump.



NOTE

- For more information about BUS connections, please contact your distributor.

5.13. Energy meter

The heat pump allows MODBUS communication with energy meters supplied by VOLTA HEAT PUMPS. Before installing the energy meter, carefully read its assembly instructions.

Description	Signal	Connector
Energy meter BUS communication	ModBus RS485	FBus2

Table 5.12. Data bus connection terminals for the energy meter.

Follow the recommendations below to connect the energy meter to the heat pump.

- Use a three-pole, shielded AWG 20-22 cable for the connection.
- Connect the terminals in series for installations with more than one terminal in the network. The maximum length of the circuit assembly should not exceed 500 metres. For connection networks with more than two thTs, it is necessary to install a 120 Ohm heater between Rx+/Tx+ and Rx-/Tx- in the first and last terminal to prevent possible communication problems.
- To install the device supplied by VOLTA HEAT PUMPS, follow the steps in the manufacturer's installation manual included with the equipment. It is necessary to configure a 100 address on the measurement device for proper communication with your heat pump (See control applications manual).

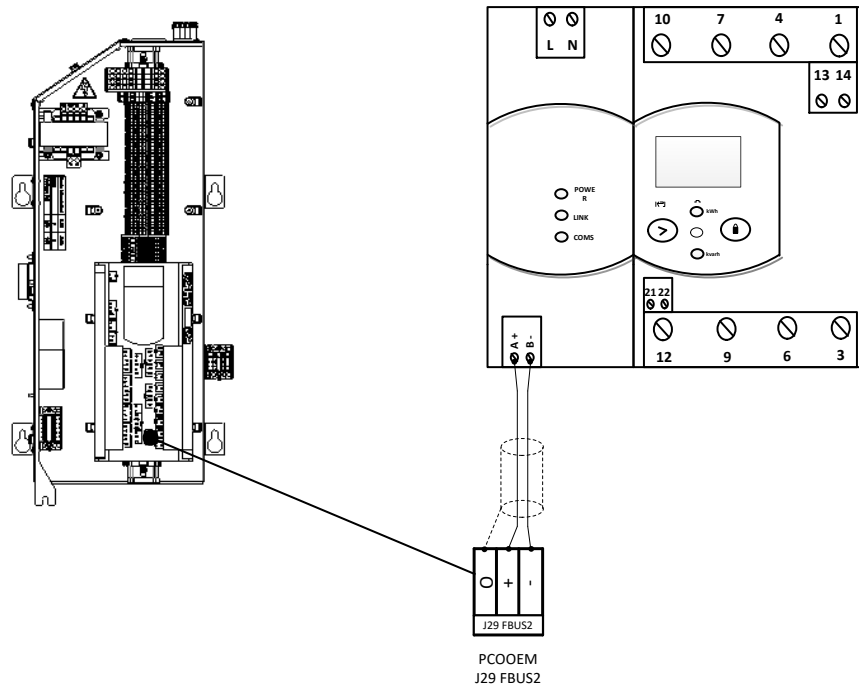

Figure 5.12. Example of connection of energy meter.

6. Start-up

Check the following items before starting up the heat pump. Not doing so could result in poor heat pump operation and/or serious heat pump damage.

1. All the hydraulic circuits of the installation have been properly filled and bled.
2. The cut-off valves of the hydraulic brine and production circuits are open.
3. An external switch has been installed to cut off all the power supply circuits of the heat pump.
4. The heat pump power supply has the proper voltage and allows sufficient consumption to start up the compressor.
5. The inside room temperature of the home is at least 18°C. Otherwise, the temperature has to be increased by auxiliary equipment.

7. Technical specifications VOLTA W XS

7.1. Component location

No.	Description	No.	Description
1	Production outlet	29	Compressor suction temp. sensor
2	Production inlet	30	Compressor drain temp. sensor
3	Brine outlet	31	Brine outlet temp. sensor
4	Brine inlet	32	Brine inlet temp. sensor
5	DHW inter-storage tank outlet	33	Production outlet temp. sensor
6	DHW inter-storage tank inlet	34	Production inlet temp. sensor
7	Evaporator (direct cycle)	35	Suction pressure transducer
8	Condenser (direct cycle)	36	Discharge pressure transducer
9	HTR system exchanger	37	Brine pressure transducer
10	Free cooling / defrosting exchanger	38	Production pressure transducer
11	Compressor	39	Suction mini-pressure switch
12	Electronic expansion valve	40	Discharge mini-pressure switch
13	Filter dryer	41	Service outlet
14	Cycle inversion valve	42	Cooling outlet inverter
15	Production circulator pump	43	Cooling inlet inverter
16	Brine circulator pump	44	Outlet resistor
17	HTR circulator pump	45	Safety thermostat
18	Brine expansion vessel	46	Electrical panel
19	Production expansion vessel	47	Tap water inlet
20	Brine safety valve	48	DHW outlet
21	Production safety valve	49	DHW Recirculation
22	HTR system retention valve	50	DHW storage tank
23	Brine discharge valve	51	DHW coil
24	Production discharge valve	52	Manual trap
25	HTR system discharge valve	53	Storage tank drain valve
26	DHW valve	54	DHW temperature sensor
27	Free cooling production valve	55	Refrigerant circuit backflow preventer
28	Free cooling brine valve	56	Refrigeration valve inverter

VOLTA W-XS-A-6-230 R290

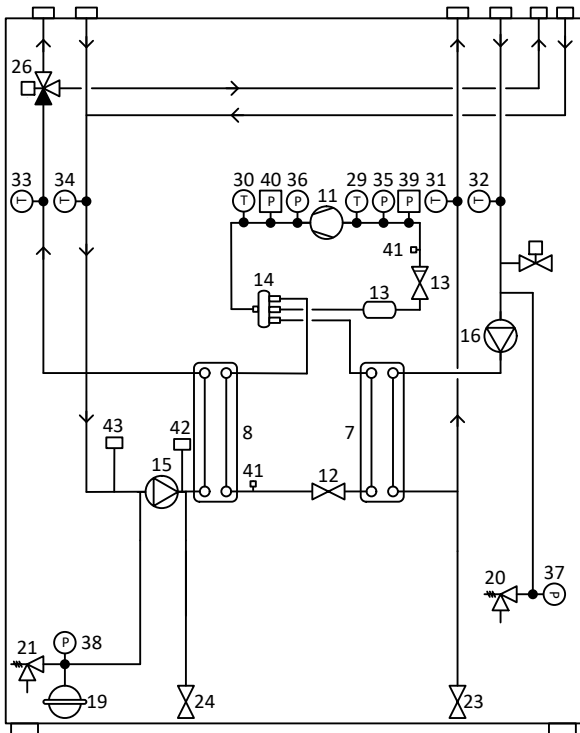

VOLTA W-XS-A-6-230 R290

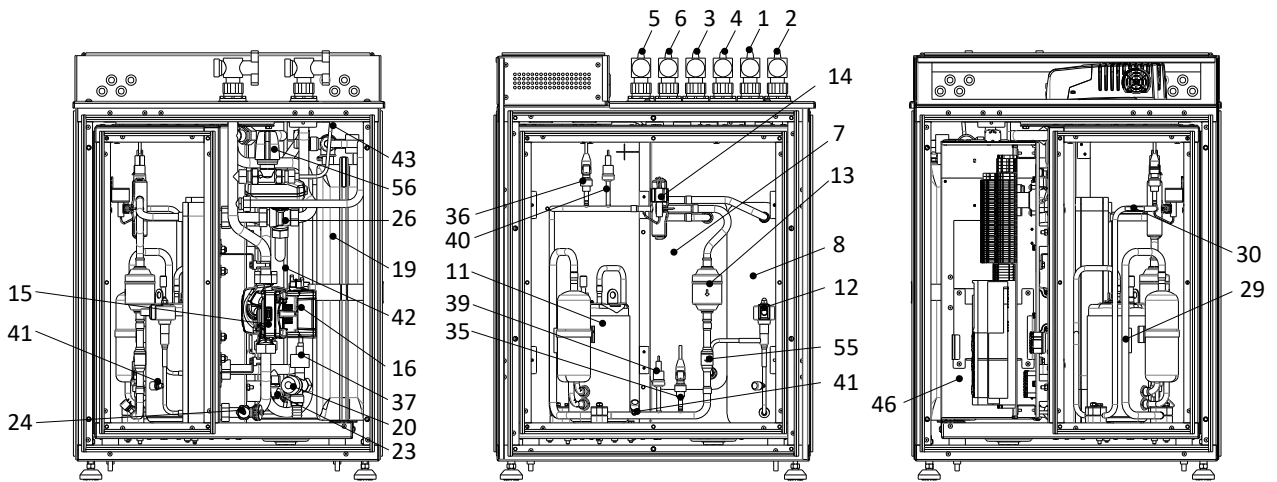

VOLTA W-XS-A-6-230 R290

EN

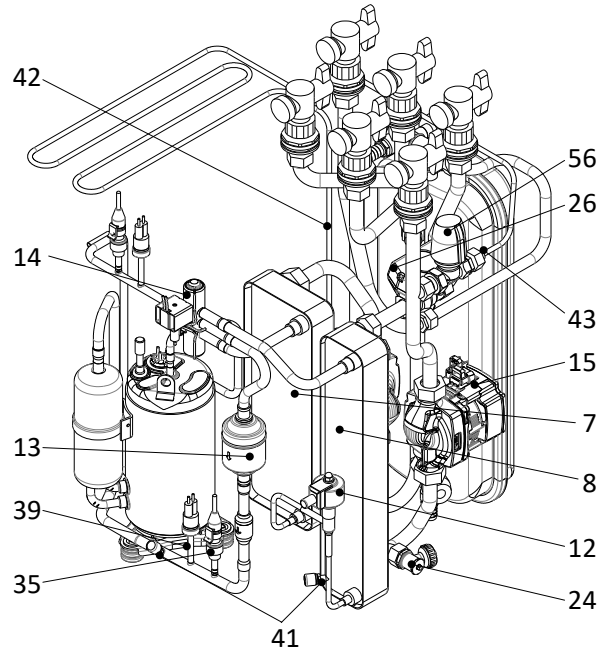
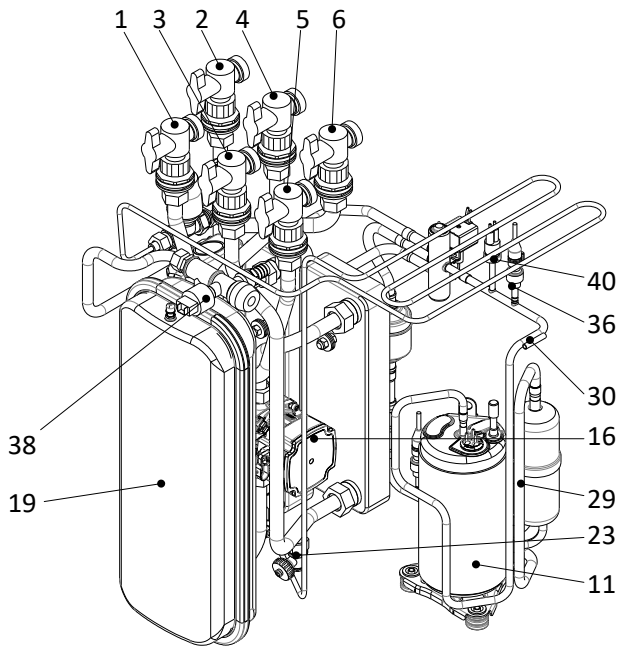

7.2. Power circuit diagram

VOLTA XS R290 monofásica

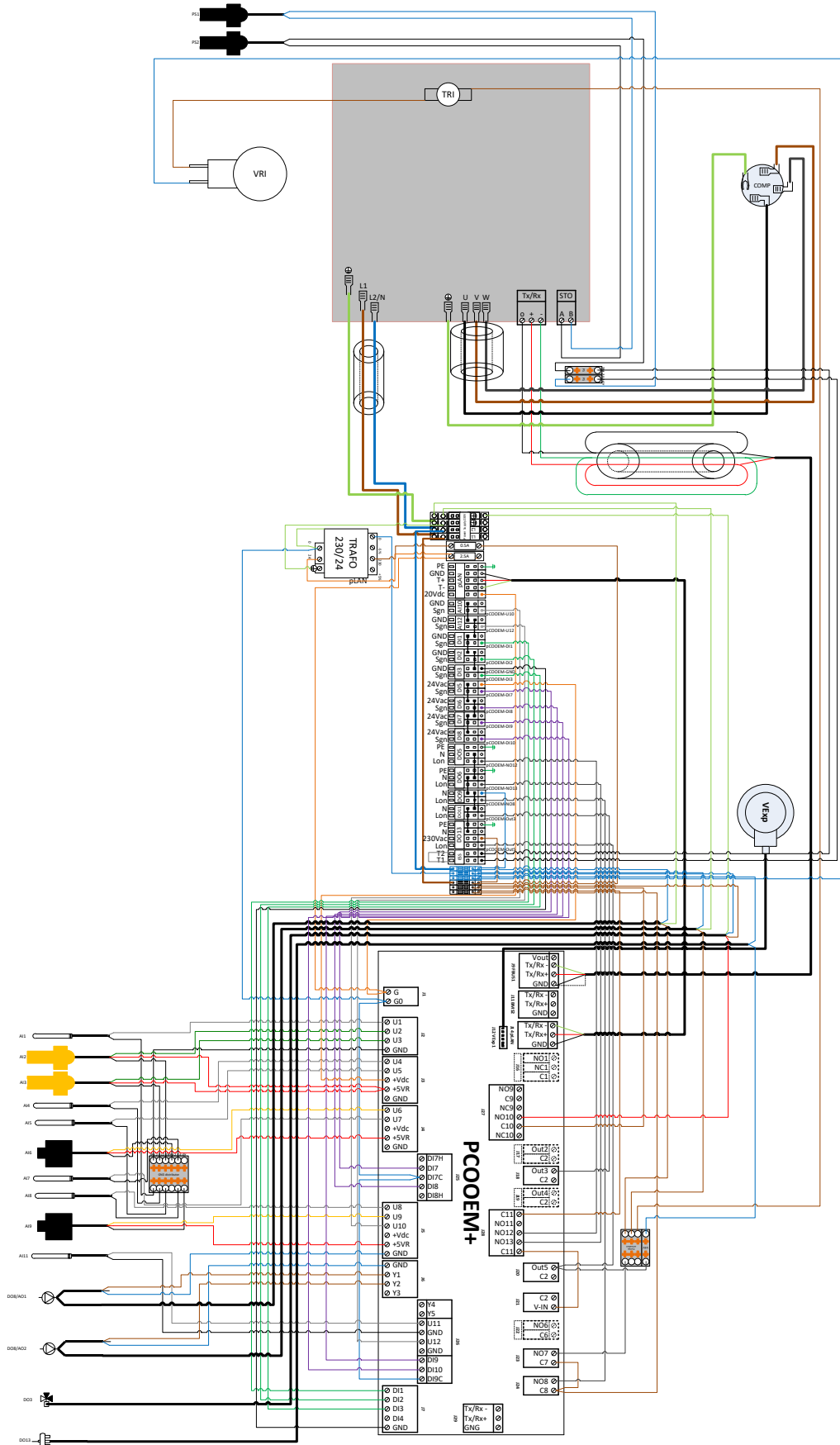

7.3. VOLTA XS R290 electrical connection tables

EN

ANALOG INPUTS			
CONNECTIONS		DESCRIPTION	
Connection terminal	Controller terminal	Type	Signal
Block I / DLT	Inverter / DLT	NTC 10K 25°C	Compressor discharge temperature
Block I / AI1	pCOOEM+ / J2 / U1	NTC 10K 25°C	Compressor suction temperature
Block I / AI2	pCOOEM+ / J2 / U2	Radiometer 0-5Vdc	Compressor suction pressure
Block I / AI3	pCOOEM+ / J2 / U3	Radiometer 0-5Vdc	Compressor discharge pressure
Block I / AI4	pCOOEM+ / J3 / U4	NTC 10K 25°C	Brine outlet temperature
Block I / AI5	pCOOEM+ / J3 / U5	NTC 10K 25°C	Brine inlet temperature
Block I / AI6	pCOOEM+ / J4 / U6	Radiometer 0-5Vdc	Brine circuit pressure
Block I / AI7	pCOOEM+ / J4 / U7	NTC 10K 25°C	Production outlet temperature
Block I / AI8	pCOOEM+ / J5 / U8	NTC 10K 25°C	Production inlet temperature
Block I / AI9	pCOOEM+ / J5 / U9	Radiometer 0-5Vdc	Production circuit pressure
Block II / AI10	pCOOEM+ / J5 / U10	NTC 10K 25°C	DHW inter-storage tank temperature
Block II / AI11	pCOOEM+ / J26 / U11	NTC 50K 25°C	Compressor discharge temperature
Block II / AI12	pCOOEM+ / J26 / U12	NTC 10K 25°C	Outdoor temperature

ANALOG OUTPUTS			
CONNECTIONS		DESCRIPTION	
Connection terminal	Controller terminal	Type	Signal
Block II / AO1	pCOOEM+ / J6 / Y1	PWM	Brine pump adjustment
Block II / AO2	pCOOEM+ / J6 / Y2	PWM	Production pump adjustment

DIGITAL INPUTS			
CONNECTIONS		DESCRIPTION	
Connection terminal	Controller terminal	Type	Signal
Block III / DI1	pCOOEM+ / J7 / DI1	Voltage-free (0V)	EVU / SG / WINTER-SUMMER / DHW
Block III / DI2	pCOOEM+ / J7 / DI2	Voltage-free (0V)	EVU / SG / WINTER-SUMMER / DHW
Block III / DI3	pCOOEM+ / J7 / DI3	Voltage-free (0V)	EVU / SG / WINTER-SUMMER / DHW
Block III / DI5	pCOOEM+ / J25 / DI7	24Vdc / 24Vac	DG1 heating request
Block III / DI6	pCOOEM+ / J25 / DI8	24Vdc / 24Vac	DG1 cooling request
Block III / DI7	pCOOEM+ / J26 / DI9	24Vdc / 24Vac	DG2 heating request
Block III / DI8	pCOOEM+ / J26 / DI10	24Vdc / 24Vac	DG2 cooling request

DIGITAL OUTPUTS			
CONNECTIONS		DESCRIPTION	
Connection terminal	Controller terminal	Type	Signal
Block I / DO3	pCOOEM+ / J27 / NO10-NC10	Activation 230Vac / 2A max	DHW production
Block IV / DO5	pCOOEM+ / J28 / NO12	Activation 230Vac / 2A max	DG1 group production
Block IV / DO6	pCOOEM+ / J28 / NO13	Activation 230Vac / 2A max	DG2 group production
Block I / DO8	pCOOEM+ / J23 / NO7	Activation 230Vac / 2A max	Compressor + circulator activation
Block IV / DO9	pCOOEM+ / J24 / NO8	Activation 230Vac / 2A max	Alarm signal
Block IV / DO11	pCOOEM+ / J18 / Out3	Activation 230Vac / 2A max	DHW inter-storage tank resistor
Block V / DO13	pCOOEM+ / J20 / Out5	Activation 230Vac / 2A max	Active cooling production
Block III / DCV	pCOOEM+ / J23 / NO7	Refrigeration inverter	Refrigeration valve inverter

PROTECTIONS			
CONNECTIONS		DESCRIPTION	
Connection terminal	Controller terminal	Type	Signal
Block I / PS1	-	Safety switch	Low pressure switch
Block I / PS2	-	Safety switch	High pressure switch
Block II / ESS	Inverter / STO	Safety switch	External safety switch

COMMUNICATIONS			
CONNECTIONS		DESCRIPTION	
Serial port	Controller terminal	Type	Signal
Plan	pCOOEM+ / J15 Phone connector	RJ11	Controller screen
	pCOOEM+ / J14 Plug-in connector	RS485 ModBus RTU	Controller network connector
FBus	pCOOEM+ / J9	RS485 ModBus RTU	Compressor inverter
FBus2	pCOOEM+ / J29	RS485 ModBus RTU	Outdoor bus terminals
BMS Card	pCOOEM+ / J13	RS485 ModBus RTU	Connector for remote access communication cards
BMS2	pCOOEM+ / J11	RS485 ModBus RTU	Remote access through bus
Expansion valve	pCOOEM+ / J12	Stepper motor	Unipolar valve control

7.4. Hydraulic operational area

VOLTA W-XS-A-6-230 R290

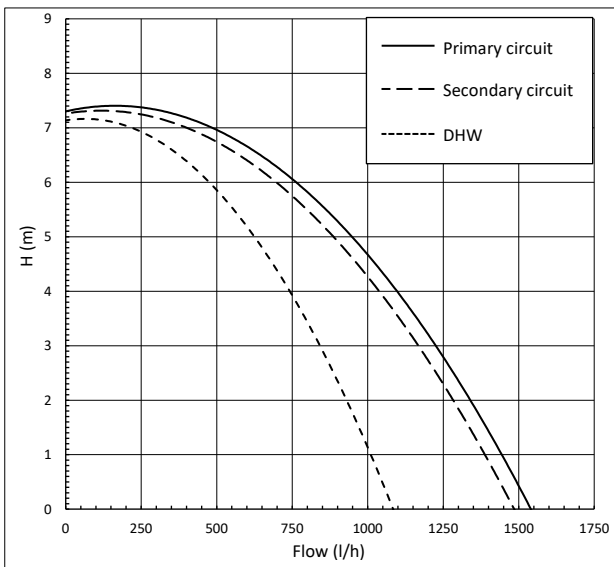

8. Operation map

VOLTA W-XS-A-6-230 R290

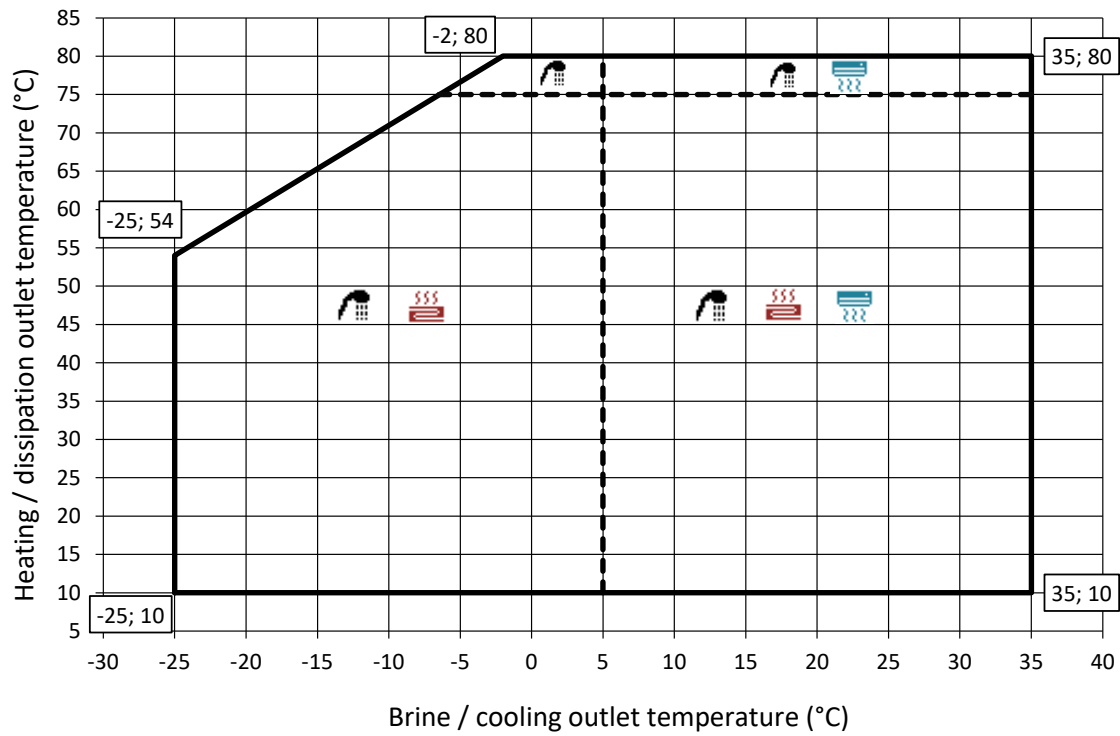

NOTE

- The maximum compressor speed is not guaranteed over the entire compressor operating map.

9. Operation curves

VOLTA W-XS-A-6-230 R290

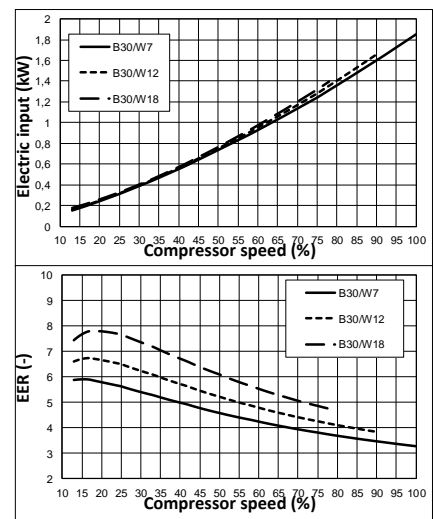
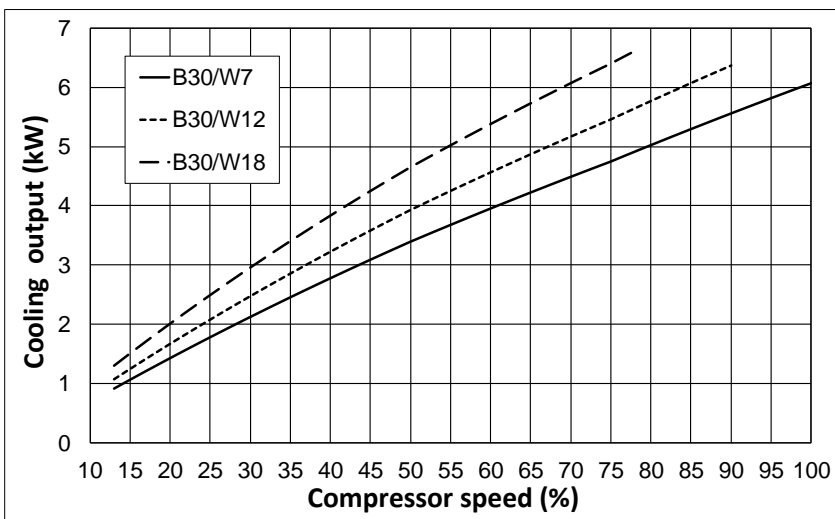
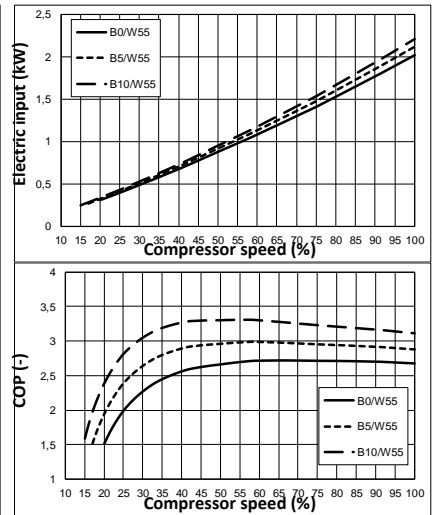
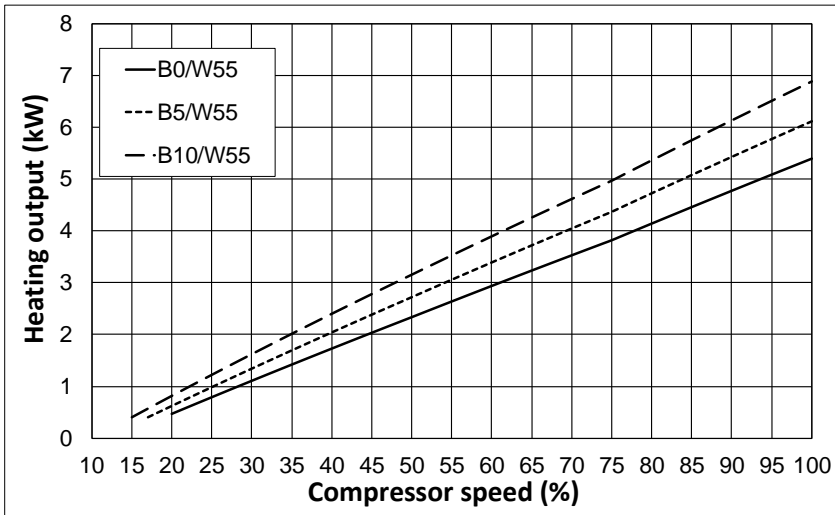
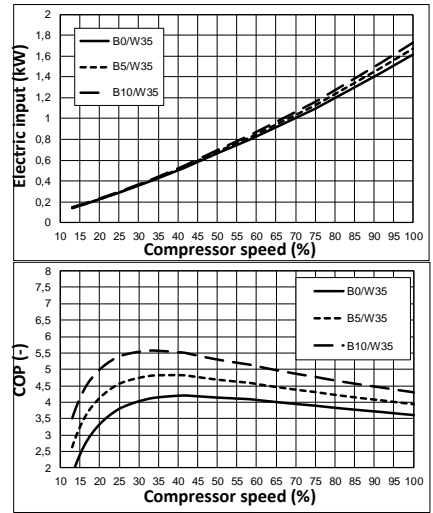
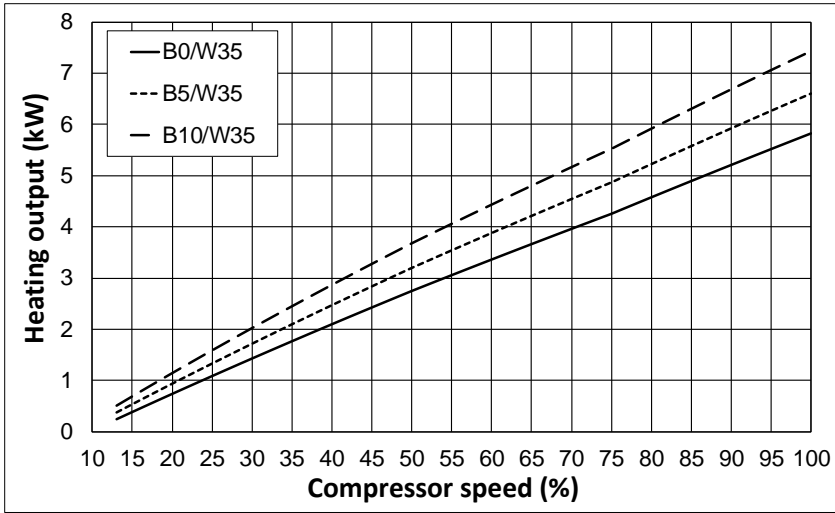

10. Technical data table



NOTE





















- In the technical data tables you will find a series of numbers in superscript format, the meaning of which is explained below:
 1. Replacing or combining the geothermal collector with one or more VOLTA W-O aerothermal units. Refer to the VOLTA W-O aerothermal units manual for more detailed information.
 2. In compliance with EN 14511, this includes the consumption of the circulation pumps and the compressor driver. Brine thermal gap ($\Delta T = 3 \text{ }^\circ\text{C}$) and production thermal gap ($\Delta T = 5 \text{ }^\circ\text{C}$).
 3. Pending certification
 4. Considering a heat ramp of 20°C to 50°C in absence of consumption.
 5. Considering support provided by the emergency electrical resistor or the HTR system. Maximum DHW temperature with the HTR system can be limited by the compressor discharge temperature.
 6. In compliance with EN 12102, this includes the acoustic insulation kit of the compressor.
 7. Start-up intensity depends on the operating conditions of the hydraulic circuits.
 8. The admissible voltage range for proper operation of the heat pump is $\pm 10\%$.
 9. Maximum consumption can vary significantly according to working conditions, or if the compressor's range of operation is restricted. Refer to the technical service manual for more detailed information.
 10. The installation must be carried out in such a way as to guarantee the nominal flow rates, which will be calculated for the maximum powers with a temperature differential of 5°C . On the other hand, to ensure correct compressor start-up, the installation must guarantee a flow rate greater than that resulting from the formula:

$Q \geq 1.2 \times P_{ref}$, where:

 - i. Q = flow in litres per minute.
 - ii. P_{ref} = cooling power at 25% of compressor, see operating curve graphs.

W-XS-A-6-230 R290 specifications		Units	W-XS-A-6-230 R290
Application	Place of installation	-	Indoors
	Type of brine system	-	Geothermal
	Heating	-	✓
	Integrated active cooling	-	✓
Performance	Compressor modulation	%	12,5 - 100
	Heating power ² , B0W35 ¹⁰	kW	1 - 6
	COP _{max} ² / Heating power ² B0W35 ¹⁰	- / kW	4,3 / 2,6
	Active cooling power ² , B35W7 ¹⁰	kW	1 - 6
	EER ² / Active cooling power ² B35W7 ¹⁰	- / kW	4,4 / 2
	Maximum DHW temperature without backup	°C	75
	Maximum DHW temperature with backup ⁵	°C	80
	Sound power level ⁶	dBA	33 - 44
Operation limits	Energy label / η_s average climate	--	A+++ / 182%
	Heating temperatures / Maximum setpoint	°C	10 - 75 / 75
	Cooling temperatures / Min. setpoint	°C	5 - 35 / 7
	Brine heating temperatures	°C	-25 - 35
	Dissipation cooling temperatures	°C	10 - 70
	Min./max. refrigerant circuit pressure	bar	0,5 / 32
	Production circuit pressure	bar	0,5 - 3 / 1,5
Brine circuit pressure	bar	0,5 - 6	
Working fluids	Refrigerant type / GWP	--	R290 / 3
	Charge / T CO ₂ eq	Kg/ton	0,150 / 0
	Compressor oil type / charge	kg	PZ46M / 0,3
Electrical control data	1/N/PE 230 V / 50-60 Hz ⁸	-	✓
	Maximum recommended external protection ⁹	A	C16A
	Primary transformer circuit fuse	A	0,5
	Secondary transformer circuit fuse	A	2,5
Heat pump electrical data: Single phase	1/N/PE 230 V / 50-60 Hz ⁸	-	✓
	Maximum recommended external protection ⁹	A	C16A
	Maximum consumption ² , B0W35	kW/A	1,6 / 6,8
	Maximum consumption ² , B0W55	kW/A	2,0 / 8,6
	Start-up intensity minimum/maximum ⁷	A	0,6 / 1,8
Correction of cosine ϕ	-	0,96 - 1	
Dimensions and weight	Height x width x depth	mm	790 x 595 x 575
	Empty weight (without assembly)	kg	107

11. Symbols

	DHW circuit		3-way valve open/closed
	Pool		3-way thermostatic valve
	Heating system		3-way modulating valve 0-10Vdc
	Cooling system		Check valve
	NTC temperature sensor		Cut-off valve
	Relay thermostat		Safety valve
	Data bus communication terminal		Differential pressure valve
	Circulator pump		Particulate filter
	Direct outlet unit		Heat exchanger
	Outlet unit with mixture		Outlet pipe
	Electrical heater		Return pipe
	Drain defrost heater		Flexible hose
	Expansion vessel		Drain

CE



VOLTA Heat Pumps

www.voltaheatpumps.com

Rúa das Pontes 25, 36350 Nigrán (Pontevedra) Spain

contact@voltaheatpumps.com

+34 986 262 184

VOLTA XS Gen1 TECHNICAL service manual Version 00.1X/2024

The manufacturer reserves the right to make any necessary changes to the contents of this manual without prior notice.